



# ORIENT

## Photo coupler

### Product Data Sheet

Part Number: OR-343

Customer: \_\_\_\_\_

Date: \_\_\_\_\_

**SHENZHEN ORIENT COMPONENTS CO., LTD**

Block A 3rd Floor No.4 Building, Tian'an Cyber Park, Huangge Rd, LongGang Dist, Shenzhen, GD

TEL: 0755-29681816

FAX: 0755-29681200

[www.orient-opto.com](http://www.orient-opto.com)

**1. Features**

- (1) 4.0 A maximum peak output current
- (2) 3.0 A minimum peak output current
- (3) Rail-to-rail output voltage
- (4) 200 ns maximum propagation delay
- (5) 70 ns maximum propagation delay difference
- (6) LED current input with hysteresis
- (7) 20 kV/μs minimum Common Mode Rejection (CMR) at VCM = 1500 V
- (8) ICC = 3.0 mA maximum supply current
- (9) Under Voltage Lock-Out protection (UVLO) with hysteresis
- (10) Wide operating VCC Range: 15 to 35 V
- (11) Industrial temperature range: -40° C to 105° C
- (12) Safety approval
  - UL approved(No.E323844)
  - VDE approved(No.40029733)
  - CQC approved (No.CQC19001231480 )
- (13) In compliance with RoHS, REACH standards
- (14) MSL Level 1

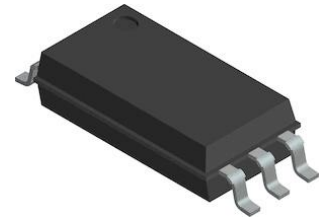

**2. Description**

The OR-343 contains an AlGaAs LED, which is optically coupled to an integrated circuit with a power output stage. This optocoupler is ideally suited for driving power IGBTs and MOSFETs used in motor control inverter applications. The high operating voltage range of the output stage provides the drive voltages required by gate controlled devices. The voltage and high peak output current supplied by this optocoupler make it ideally suited for direct driving IGBT with ratings up to 1200 V/ 100 A. For IGBTs with higher ratings, this optocoupler can be used to drive a discrete power stage which drives the IGBT gate.

**3. Application Range**

- (1)IGBT/MOSFET gate drive
- (2)AC and Brushless DC motor drives
- (3)Renewable energy inverters
- (4)Industrial inverters
- (5)Switching power supplies

**4. Functional Diagram**

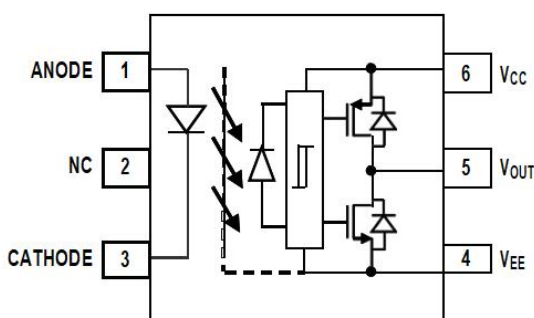

Note: A 1 F bypass capacitor must be connected between pins VCC and VEE.

Truth Table			
LED	VCC – VEE “POSITIVE GOING” (i.e., TURN-ON)	VCC – VEE “NEGATIVE GOING” (i.e., TURN-OFF)	VO
OFF	0 – 30 V	0 – 30 V	LOW
ON	0 – 11.0 V	0 – 9.5 V	LOW
ON	11.0 – 13.5 V	9.5 – 12.0 V	TRANSITION
ON	13.5 – 30 V	12.0 – 30 V	HIGH

**5. Absolute Maximum Ratings (Ta=25°C)**

Parameter		Symbol	Rated Value	Unit
Input	Average Forward Input Current	$I_F$	25	mA
	Reverse Input Voltage	$V_R$	5	V
Output	“High” Peak Output Current	$I_{OH(PEAK)}$	4	A
	“Low” Peak Output Current	$I_{OL(PEAK)}$	4	A
	Output Collector Power Dissipation	$P_O$	700	mW
Total Power Dissipation		$P_T$	745	mW
Total Output Supply Voltage		$V_{CC} - V_{EE}$	35	V
Total Output Supply Voltage (90°C)		$V_{CC} - V_{EE}$	30	V
Input Current (Rise/Fall Time)		$t_{r(IN)} / t_{f(IN)}$	500	ns
Insulation Voltage		$V_{iso}$	5000	V <sub>rms</sub>
Working Temperature		$T_{opr}$	-40 ~ + 105	°C
Storage Temperature		$T_{stg}$	-55 ~ + 125	
*2 Soldering Temperature		$T_{sol}$	260	

\*1. Room temperature = 25 °C. Exceeding the maximum absolute rating can permanently damage the device. Working long hours at the maximum absolute rating can affect reliability.

\*2. soldering time is 10 seconds.

## 6. Electrical Optical Characteristics

Unless otherwise noted, all typical values are at  $T_A = 25^\circ\text{C}$ ,  $V_{CC} - V_{EE} = 30\text{V}$ ,  $V_{EE} = \text{Ground}$ ; all minimum and maximum specifications are at recommended operating conditions ( $T_A = -40$  to  $105^\circ\text{C}$ ,  $I_F(\text{ON}) = 7$  to  $16\text{mA}$ ,  $V_F(\text{OFF}) = -3.6$  to  $0.8\text{V}$ ,  $V_{EE} = \text{Ground}$ ,  $V_{CC} = 15$  to  $30\text{V}$ ).

Parameter	Symbol	Min.	Typ.	Max.	Units	Test Conditions
High Level Output Current	$I_{OH}$	-1.0	-2.7	—	A	$V_O = (V_{CC} - 4V)$
		-3.0	—	—		$V_{CC} - V_O \leq 15V$
Low Level Output Current	$I_{OL}$	1.0	3.4	—	A	$V_O = (V_{EE} + 2.5V)$
		3.0	—	—		$V_{CC} - V_O \leq 15V$
High Output Transistor RDS(ON)	$R_{DS,OH}$	—	1.7	3.0		$I_{OH} = -2.5\text{A}$
Low Output Transistor RDS(ON)	$R_{DS,OL}$	—	0.8	1.8		$I_{OH} = 2.5\text{A}$
High Level Output Voltage	$V_{OH}$	$(V_{CC} - 0.3)$	$(V_{CC} - 0.2)$	—	V	$I_O = -100\text{mA}$
		—	$V_{CC}$	—	V	$I_O = 0\text{mA}$ , $I_F = 10\text{mA}$
Low Level Output Voltage	$V_{OL}$	—	0.1	0.2	V	$I_O = 100\text{mA}$
High Level Supply Current	$I_{CCH}$	—	1.48	3.0	mA	$R_g = 10\Omega$ , $C_g = 25\text{nF}$ , $I_F = 10\text{mA}$
Low Level Supply Current	$I_{CCL}$	—	1.58	3.0	mA	$R_g = 10\Omega$ , $C_g = 25\text{nF}$ , $V_F = 0\text{V}$
Threshold Input Current Low to High	$I_{FLH}$	—	1.79	4.0	mA	$R_g = 10\Omega$ , $C_g = 25\text{nF}$ , $V_O > 5\text{V}$
Threshold Input Voltage High to Low	$V_{FHL}$	0.8	—	—	V	
Input Forward Voltage	$V_F$	1.2	1.55	1.95	V	$I_F = 10\text{mA}$
Temperature Coefficient of Forward Voltage	$\Delta V_F / \Delta T_A$	—	-1.7	—	mV/ $^\circ\text{C}$	$I_F = 10\text{mA}$
Input Reverse Breakdown Voltage	$B_{VR}$	5	—	—	V	$I_R = 100\mu\text{A}$
Input Capacitance	$C_{IN}$	—	70	—	pF	$f = 1\text{MHz}$ , $V_F = 0\text{V}$
UVLO Threshold	$V_{UVLO+}$	11.0	12.7	13.5	V	$V_O > 5\text{V}$ $I_F = 10\text{mA}$
	$V_{UVLO-}$	9.5	11.2	12.0		
UVLO Hysteresis	$U_{VLOHYS}$	—	1.5	—		

## 7. Switching Characteristics

Unless otherwise noted, all typical values are at  $T_A = 25^\circ\text{C}$ ,  $V_{CC} - V_{EE} = 30\text{V}$ ,  $V_{EE} = \text{Ground}$ ; all minimum and maximum specifications are at recommended operating conditions ( $T_A = -40$  to  $105^\circ\text{C}$ ,  $I_F(\text{ON}) = 7$  to  $16\text{mA}$ ,  $V_F(\text{OFF}) = -3.6$  to  $0.8\text{V}$ ,  $V_{EE} = \text{Ground}$ ,  $V_{CC} = 15$  to  $30\text{V}$ ).

Parameter	Symbol	Min.	Typ	Max.	Units	Test Conditions
Propagation Delay Time to High Output Level	$t_{PLH}$	50	140	200	ns	$R_g = 10\ \Omega$ $C_g = 25\ \text{nF}$ $f = 20\ \text{kHz}$ Duty Cycle = 50% $I_F = 7\ \text{mA}$ to $16\ \text{mA}$ $V_{CC} = 15\ \text{V}$ to $30\ \text{V}$
Propagation Delay Time to Low Output Level	$t_{PHL}$	50	140	200	$\mu\text{s}$	
Pulse Width Distortion	PWD	—	25	70	ns	
Propagation Delay Difference Between Any Two Parts	$P_{DD}$ ( $t_{PHL} - t_{PLH}$ )	-100	—	100	ns	
Rise Time	$t_r$	—	46	—	ns	$V_{CC} = 30\ \text{V}$
Fall Time	$t_f$	—	43	—	ns	
Output High Level Common Mode Transient Immunity	$ CM_H $	20	30	—	kV/ $\mu\text{s}$	$T_A = 25^\circ\text{C}$ , $I_F = 10\text{mA}$ $V_{CC} = 30\text{V}$ , $V_{CM} = 1500\text{V}$ with split resistors
Output Low Level Common Mode Transient Immunity	$ CM_L $	20	30	—		$T_A = 25^\circ\text{C}$ , $V_F = 0\text{V}$ , $V_{CC} = 30\text{V}$ , $V_{CM} = 1500\text{V}$ with split resistors

## 8. Order Information

### Part Number

**OR-343U-Y-Z**

### Note

343= Part Number

U = Lead form option, W or W1

Y = Tape and reel option (TA,TA1 or none).

Z = 'V' code for VDE safety (This options is not necessary).

\* VDE Code can be selected.

Option	Description	Packing quantity
S(TA)	Surface mount lead form (low profile) + TA tape & reel option	1000 units per reel
S(TA1)	Surface mount lead form (low profile) + TA1 tape & reel option	1000 units per reel

## 9. Naming Rule

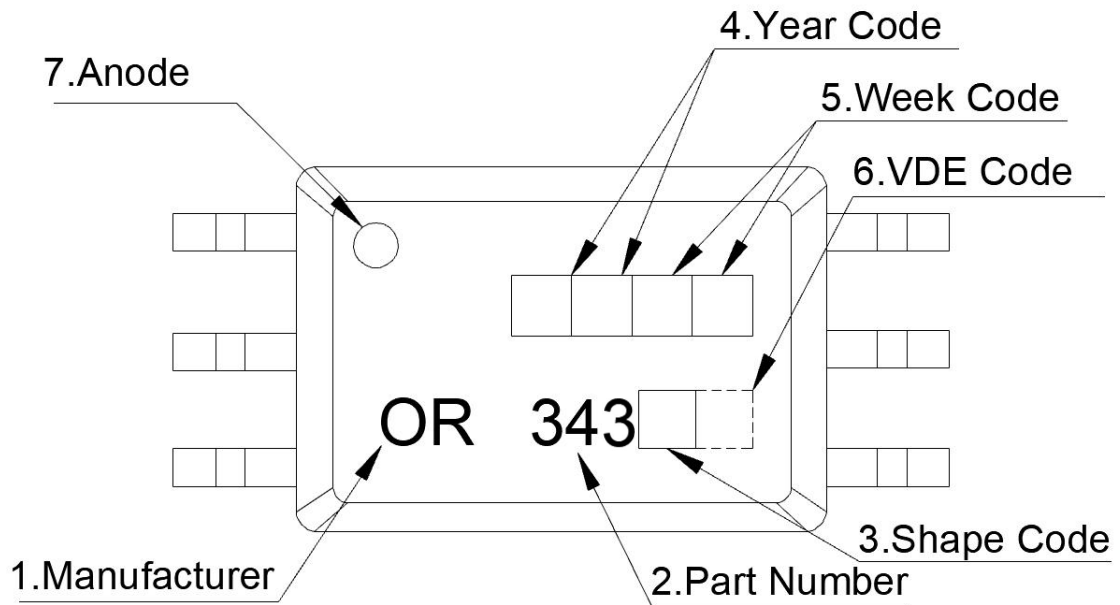

1. Manufacturer : ORIENT.
2. Part Number : 343 .
3. Shape Code  : Lead form option ,W or W1 .
4. Year Code  : '21' means '2021' and so on.
5. Week Code  : 01 means the first week, 02 means the second week and so on.
6. VDE Code  . (Optional)
7. Anode.

\* VDE Mark can be selected.

10. Package Dimension

(1).OR-343W

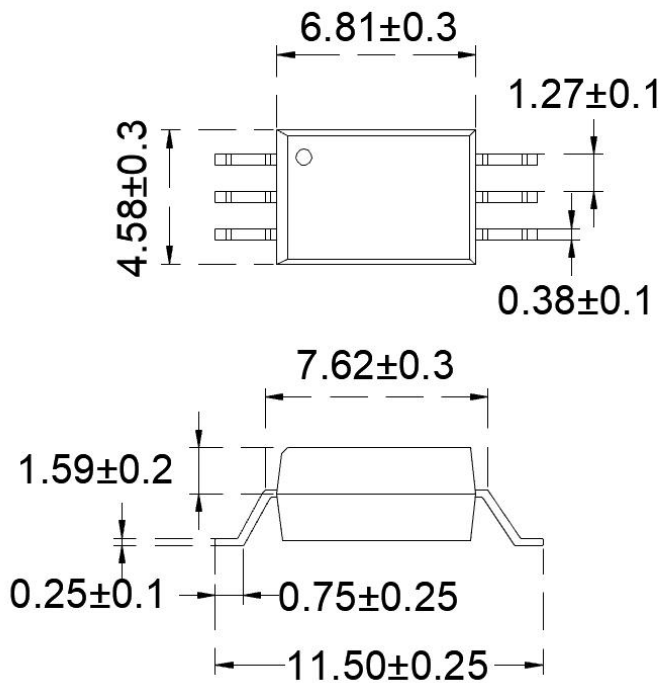

Land Pattern Recommendation

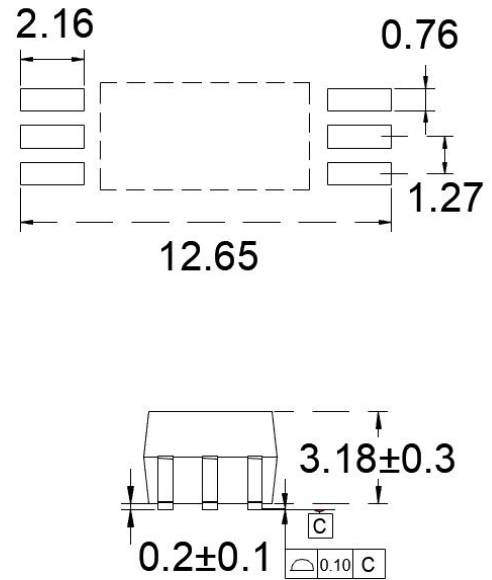

(2).OR-343W1

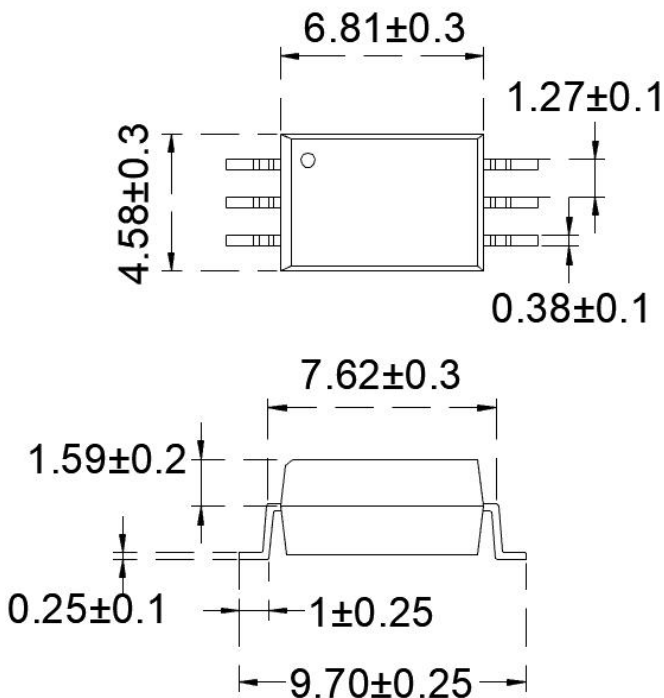

Land Pattern Recommendation

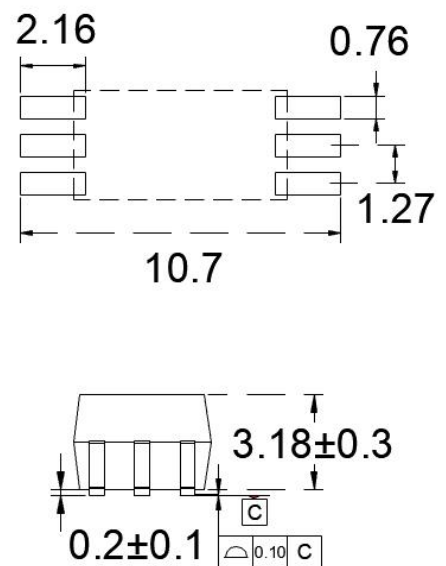

### 11. Taping Dimensions

#### (1)OR-343W-TA

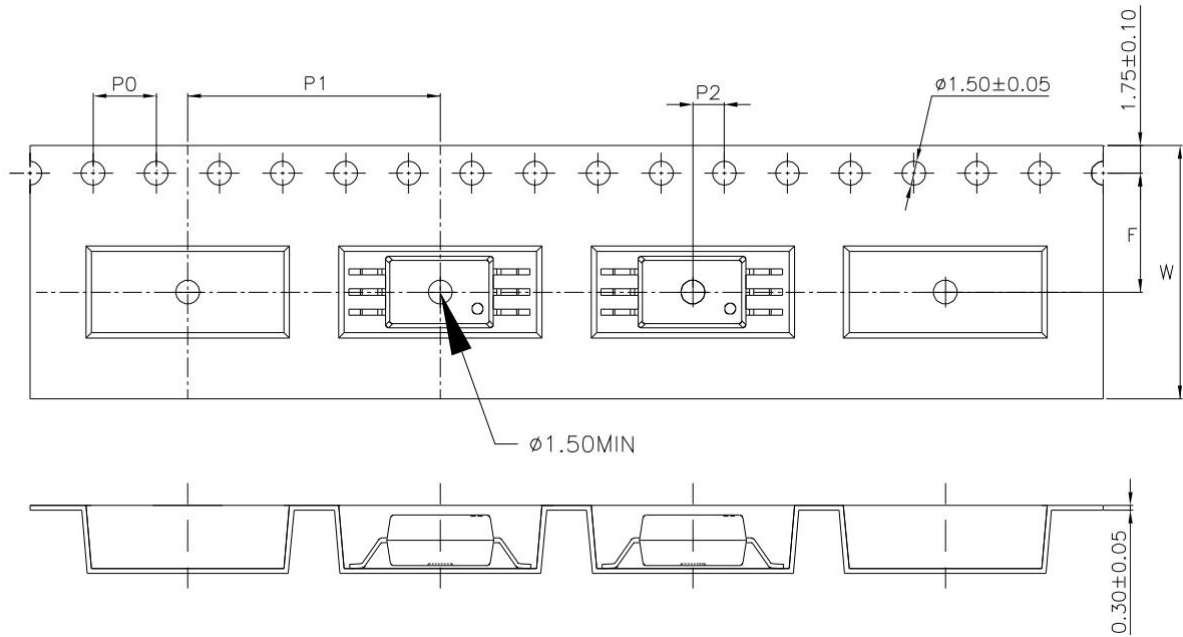

#### (2)OR-343W-TA1

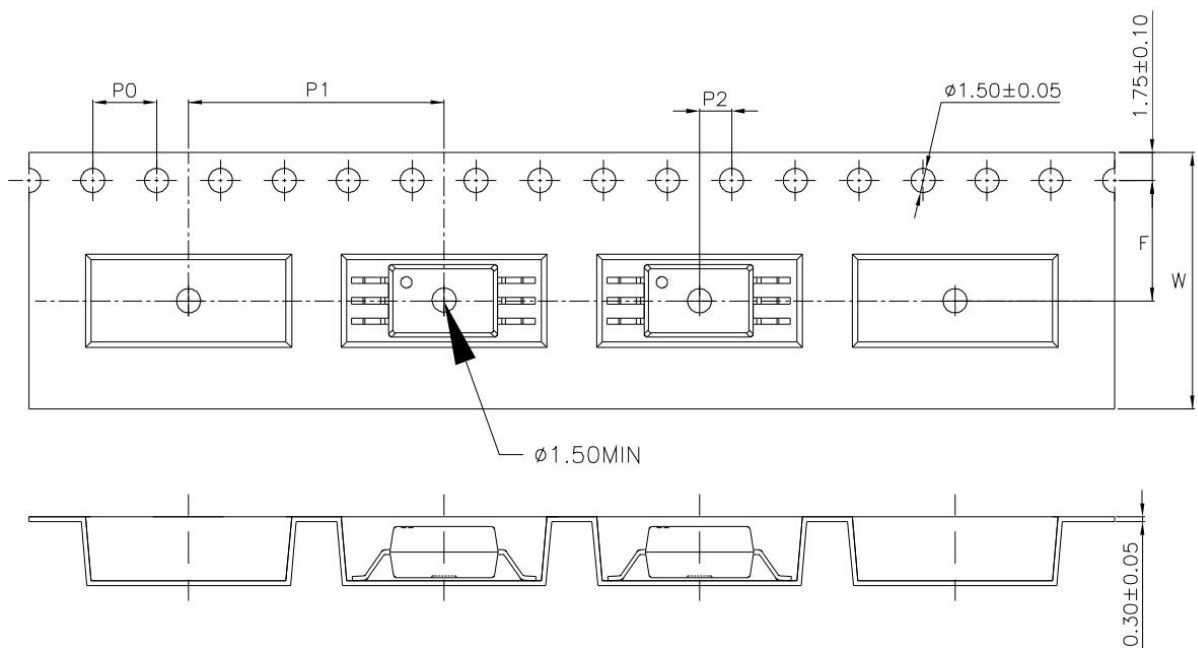



(1)OR-343W1-TA

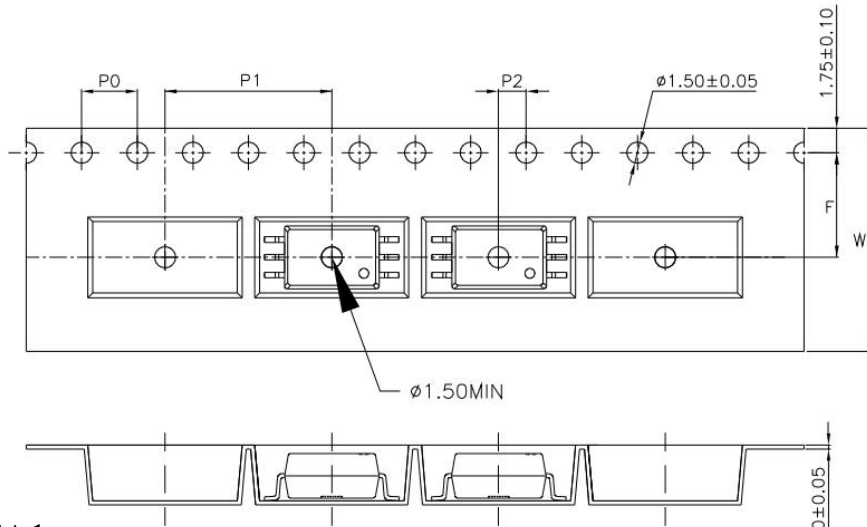

(2)OR-343W1-TA1

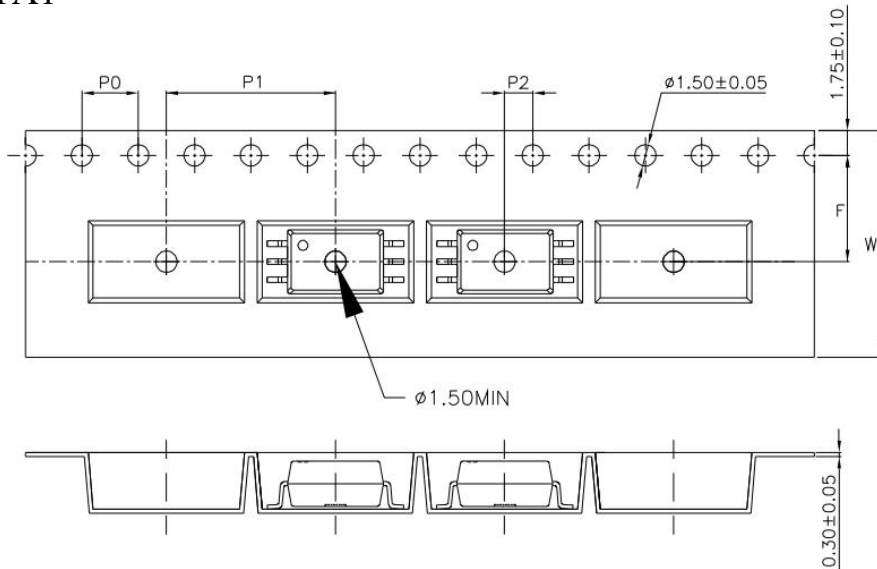

Type	symbol	Dimension in mm (inch) For W type	Dimension in mm (inch) For W1 type
bandwidth	W	$16 \pm 0.3$ (0.63)	$16 \pm 0.3$ (0.63)
pitch	P0	$4 \pm 0.1$ (0.16)	$4 \pm 0.1$ (0.16)
pitch	F	$7.5 \pm 0.1$ (0.3)	$7.5 \pm 0.1$ (0.3)
	P2	$2 \pm 0.1$ (0.079)	$2 \pm 0.1$ (0.079)
interval	P1	$16 \pm 0.1$ (0.63)	$12 \pm 0.1$ (0.47)

Encapsulation type	TA/TA1
amount (pcs)	1000

## 12. Package Dimension

### (1) package dimension

Packing Information	
Packing type	Reel type
Tape Width	16mm
Qty per Reel	1,000pcs
Small box (inner) Dimension	345*345*58.5mm
Large box (Outer) Dimension	620x360x360mm
Max qty per small box	2,000pcs
Max qty per large box	20,000pcs

### (2)Packing Label Sample

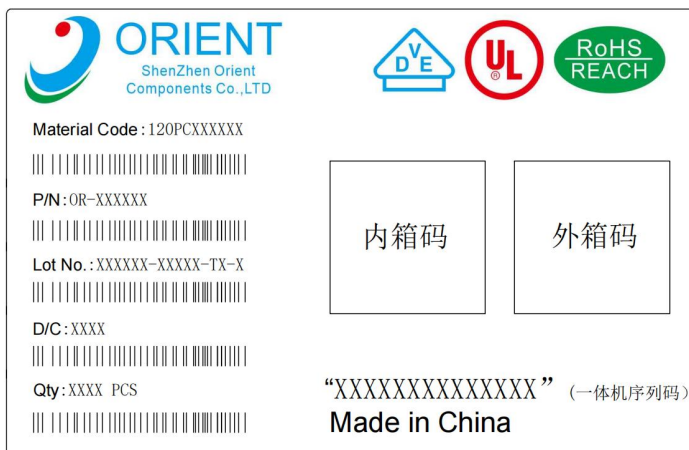

#### Note:

1. Material Code :Product ID.
2. P/N :Contents with "Order Information" in the specification.
3. Lot No. :Product data.
4. D/C :Product weeks.
5. Quantity :Packaging quantity.

### 13. Temperature Profile Of Soldering

(1).IR Reflow soldering (JEDEC-STD-020C compliant)

One time soldering reflow is recommended within the condition of temperature and time profile shown below. Do not solder more than three times.

Profile item	Conditions
Preheat - Temperature Min (T Smin ) - Temperature Max (T Smax ) - Time (min to max) (ts)	150°C 200°C 90±30 sec
Soldering zone - Temperature (TL ) - Time (t L )	217°C 60 sec
Peak Temperature	260°C
Peak Temperature time	20 sec
Ramp-up rate	3°C / sec max.
Ramp-down rate from peak temperature	3~6°C / sec
Reflow times	≤3

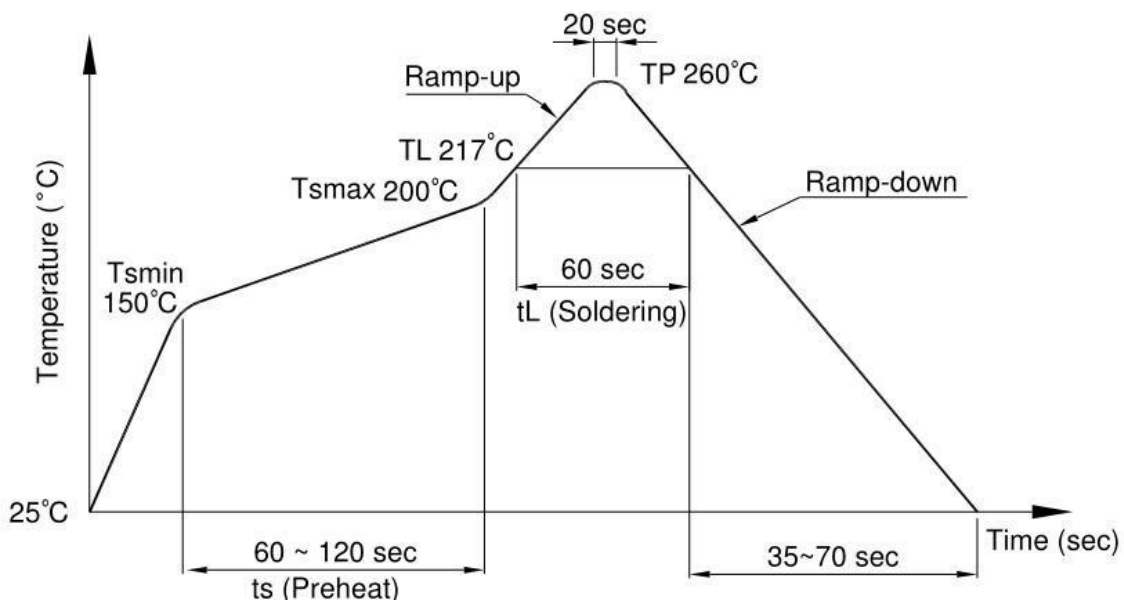

**(3) .Wave soldering (JEDEC22A111 compliant)**

One time soldering is recommended within the condition of temperature.

Temperature	260+0/-5°C
Time	10 sec
Preheat temperature	5 to 140°C
Preheat time	30 to 80 sec

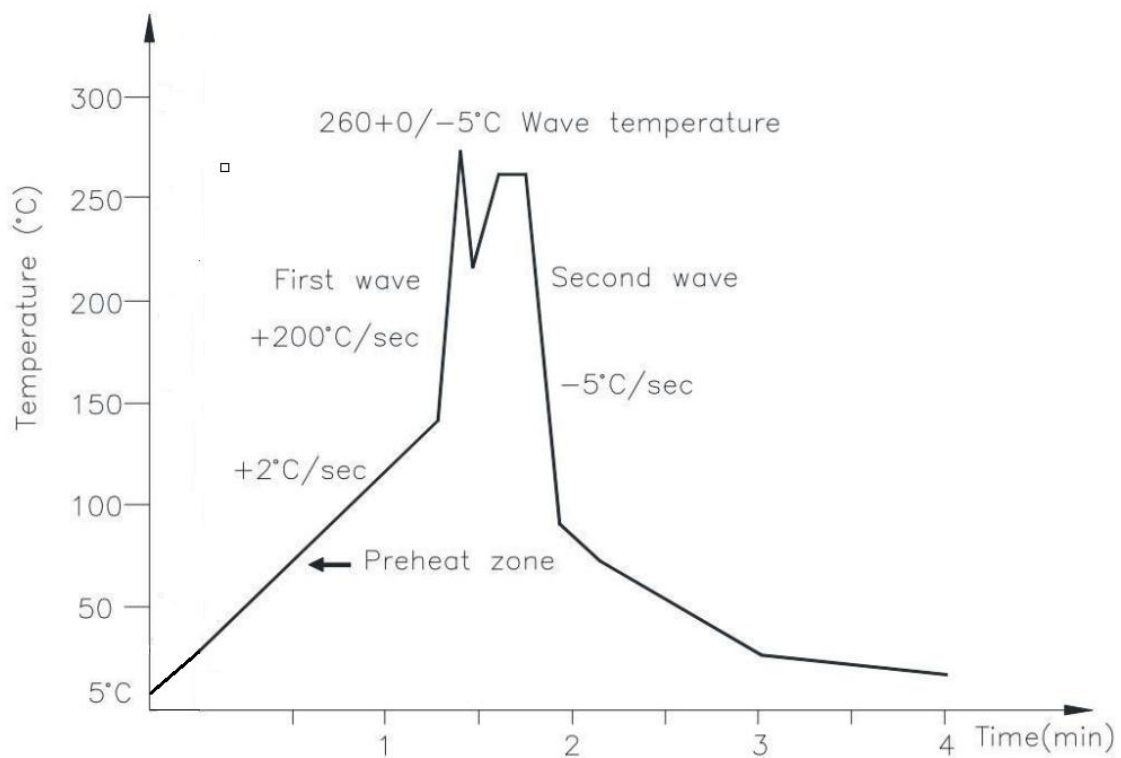

**(3).Hand soldering by soldering iron**

Allow single lead soldering in every single process. One time soldering is recommended.

Temperature	380+0/-5°C
Time	3 sec max

14. CHARACTERISTICS CURVES (TYPICAL PERFORMANCE)

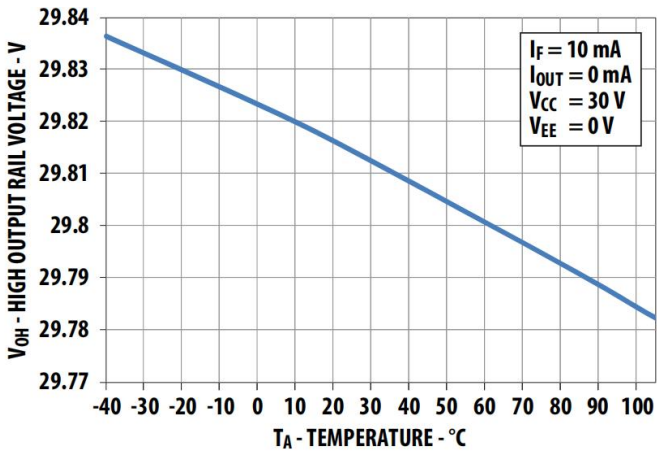

Figure 1. High output rail voltage vs. temperature

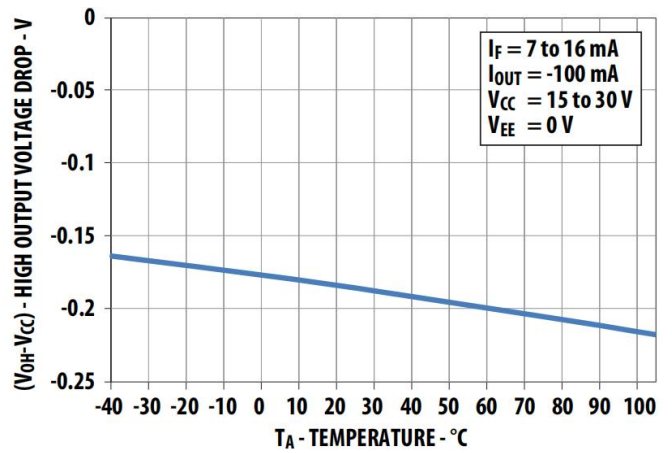

Figure 2.  $V_{OH}$  vs. temperature

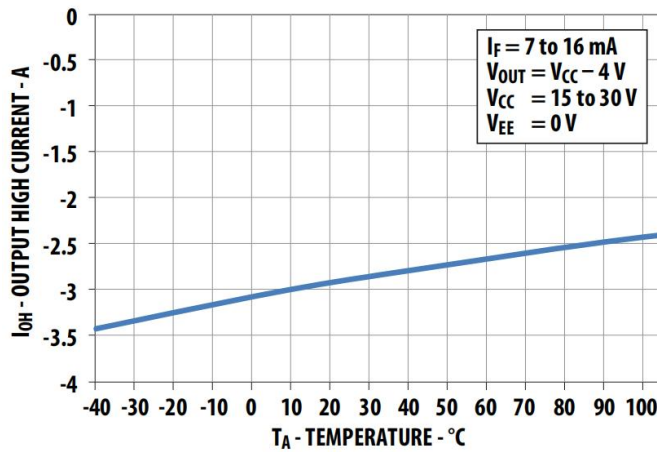

Figure 3.  $I_{OH}$  vs. temperature

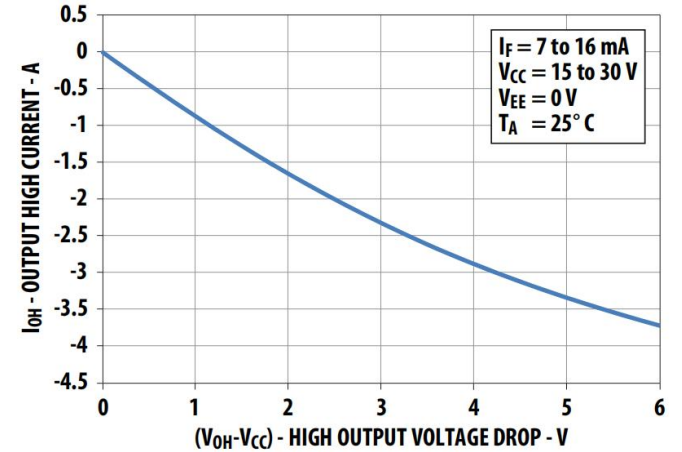

Figure 4.  $I_{OH}$  vs.  $V_{OH}$

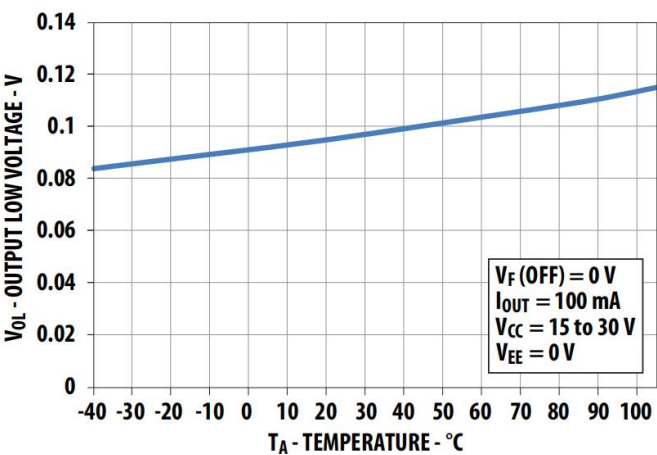

Figure 5.  $V_{OL}$  vs. temperature

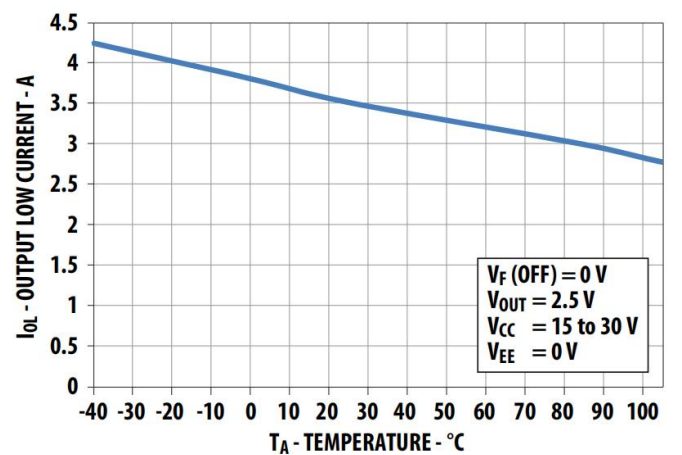

Figure 6.  $I_{OL}$  vs. temperature

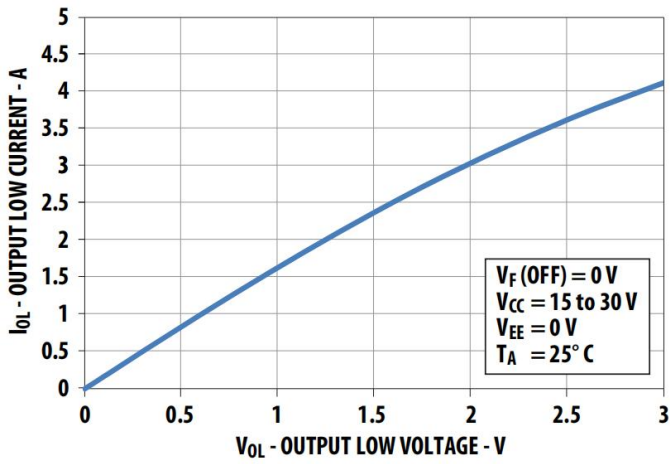

Figure 7.  $I_{OL}$  vs.  $V_{OL}$

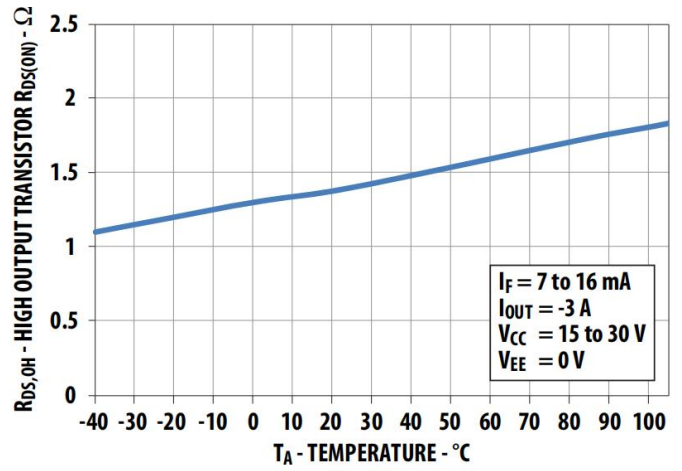

Figure 8.  $R_{DS,OH}$  vs. temperature

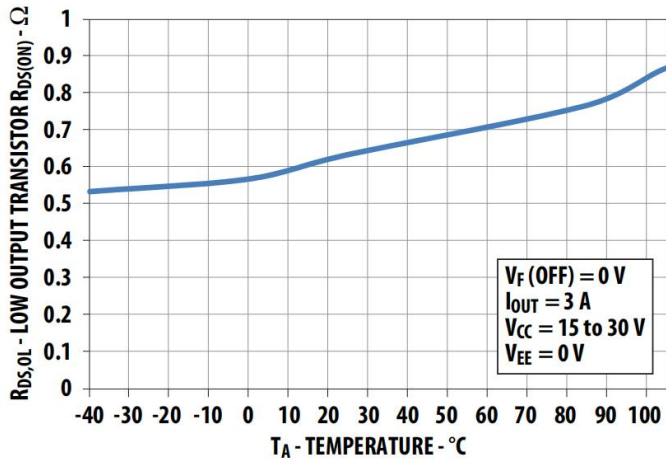

Figure 9.  $R_{DS,OL}$  vs. temperature

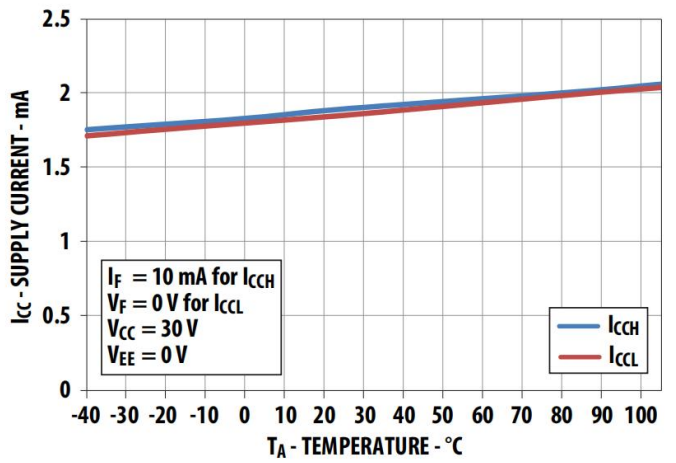

Figure 10.  $I_{CC}$  vs. temperature

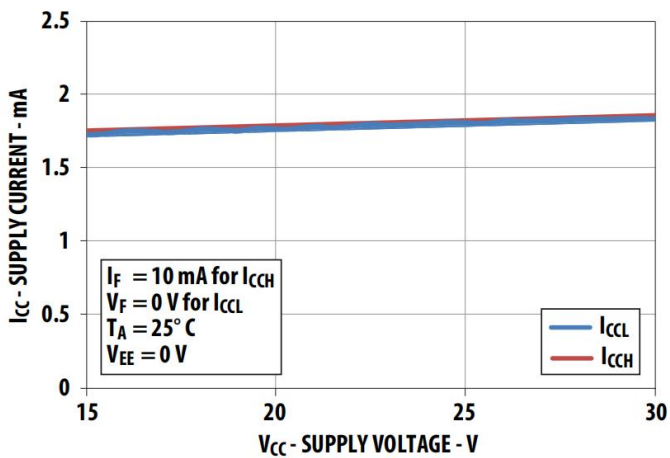

Figure 11.  $I_{CC}$  vs.  $V_{CC}$

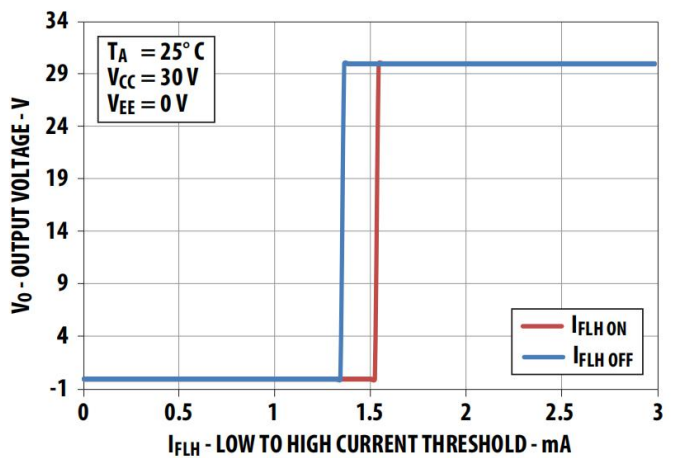

Figure 12.  $I_{FLH}$  hysteresis

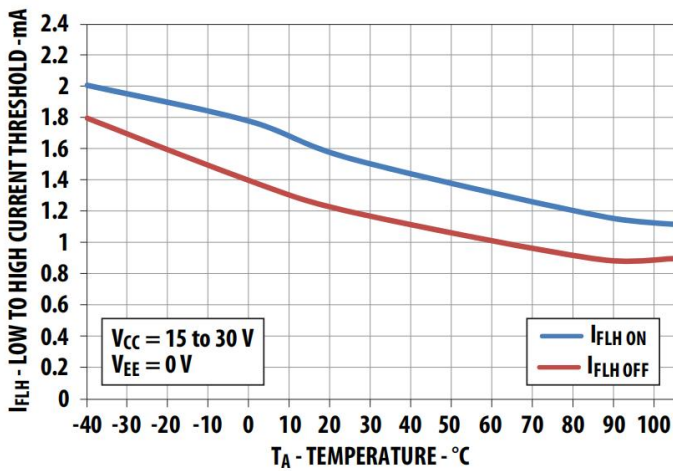

Figure 13.  $I_{FLH}$  vs. temperature

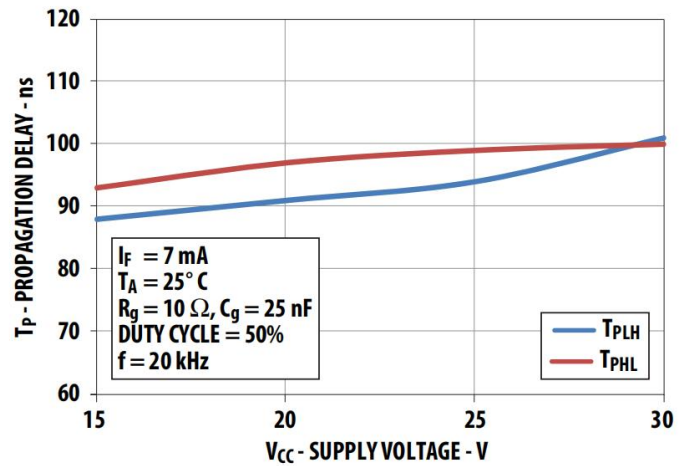

Figure 14. Propagation delays vs.  $V_{CC}$

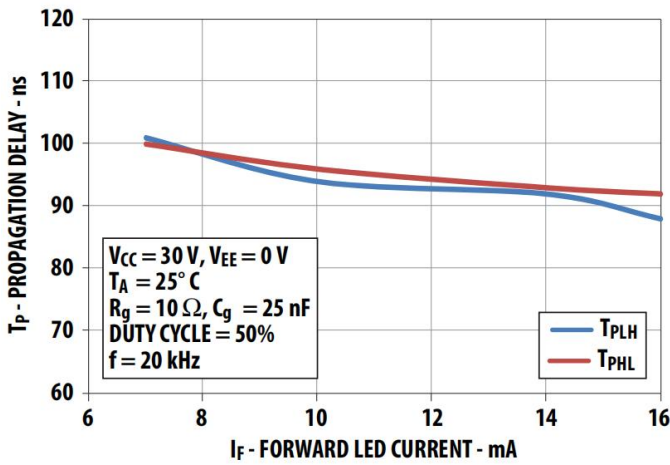

Figure 15. Propagation delays vs.  $I_F$

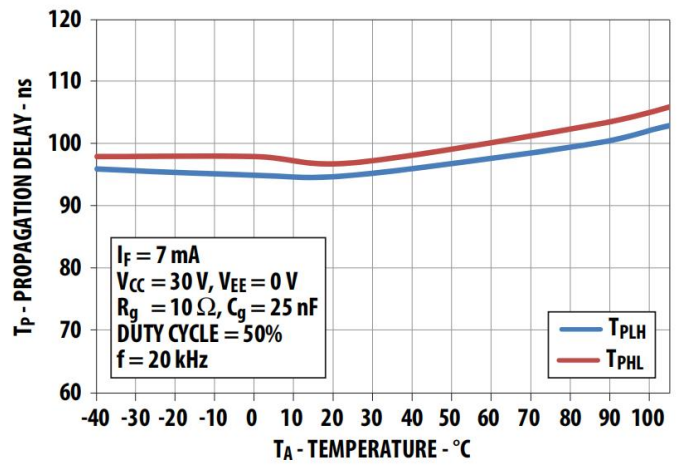

Figure 16. Propagation delays vs. temperature

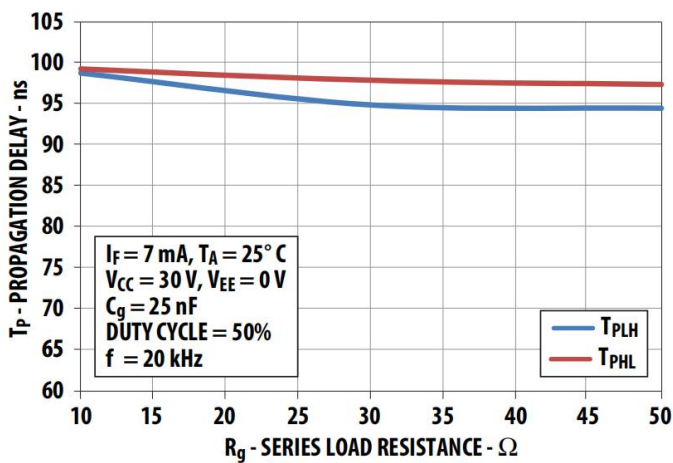

Figure 17. Propagation delay vs.  $R_g$

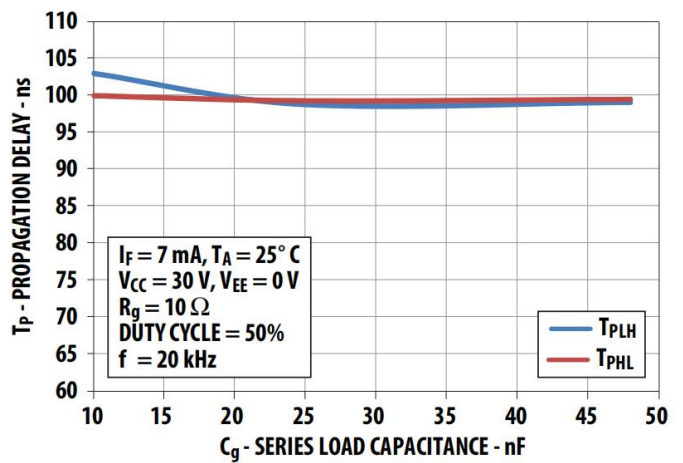

Figure 18. Propagation delay vs.  $C_g$

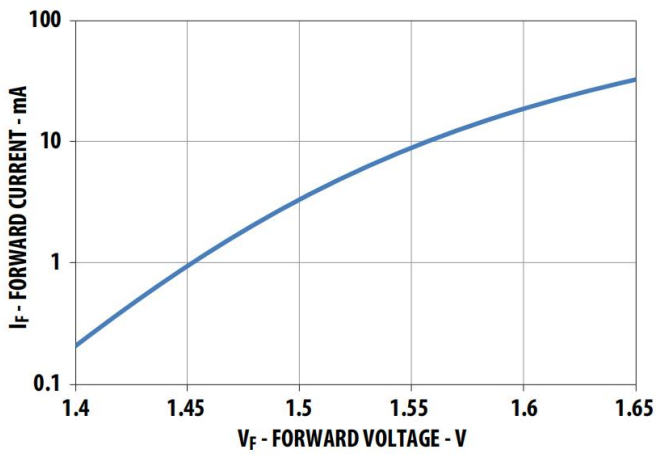

Figure 19. Input current vs. forward voltage

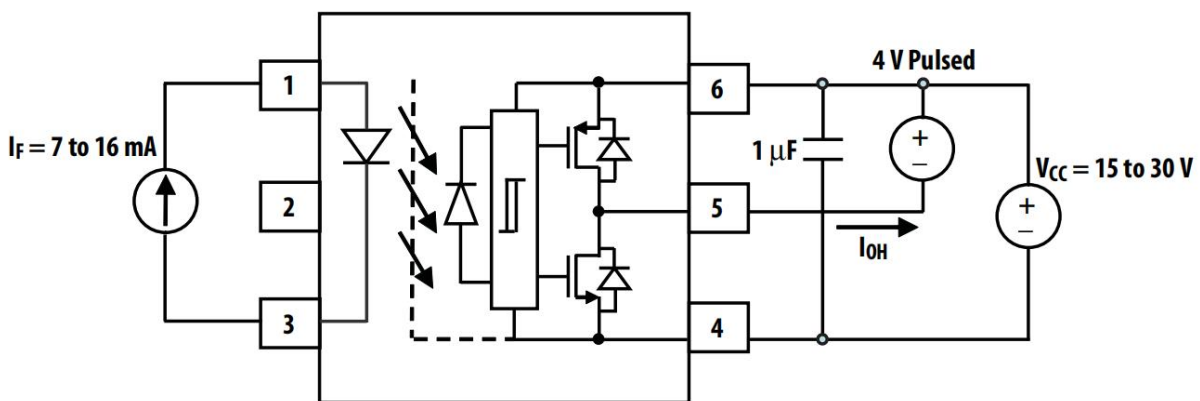

Figure 20.  $I_{OH}$  test circuit

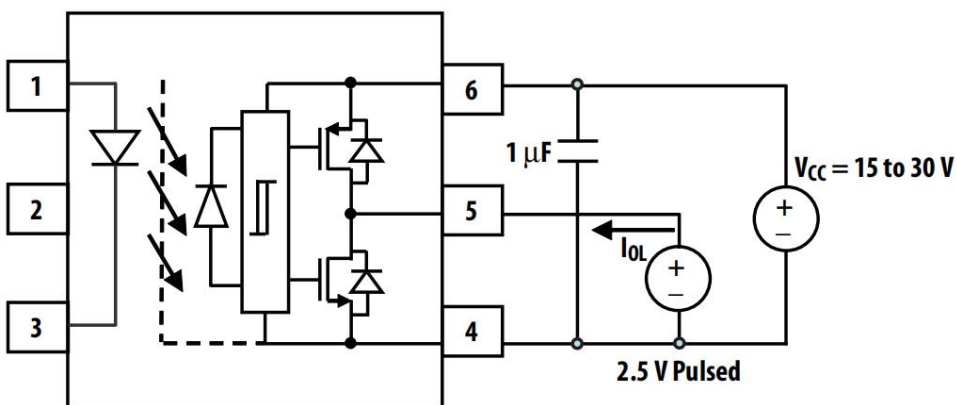

Figure 21.  $I_{OL}$  test circuit



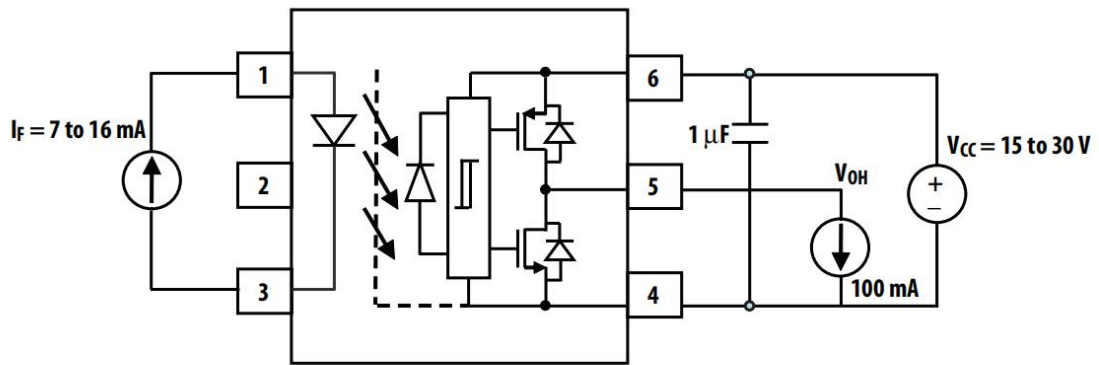

Figure 22.  $V_{OH}$  test circuit

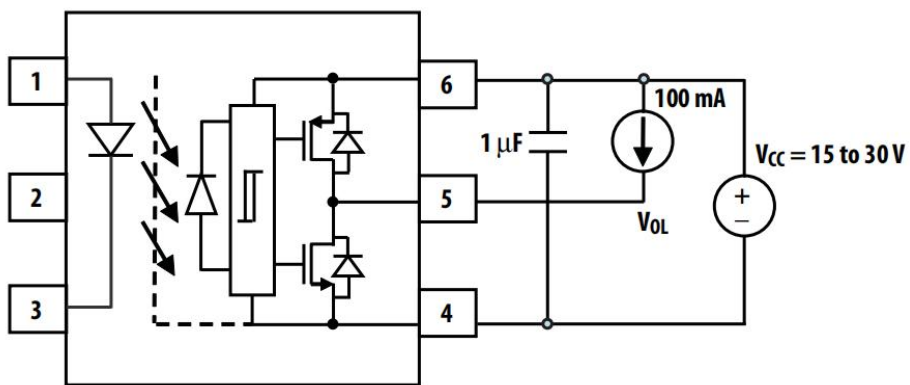

Figure 23.  $V_{OL}$  test circuit

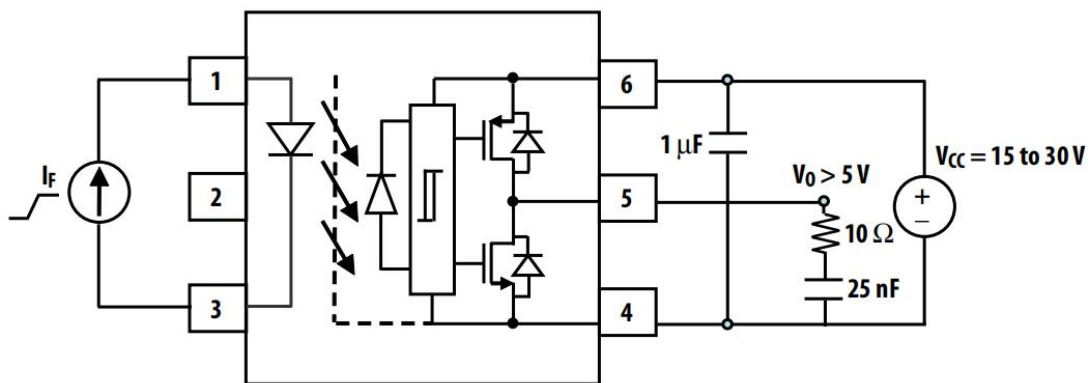

Figure 24.  $I_{FLH}$  test circuit

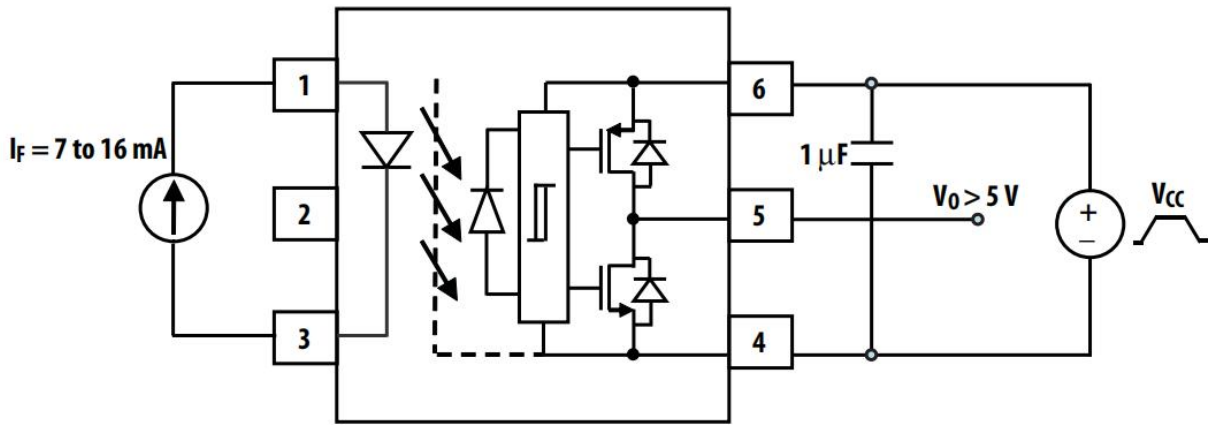

Figure 25. UVLO test circuit

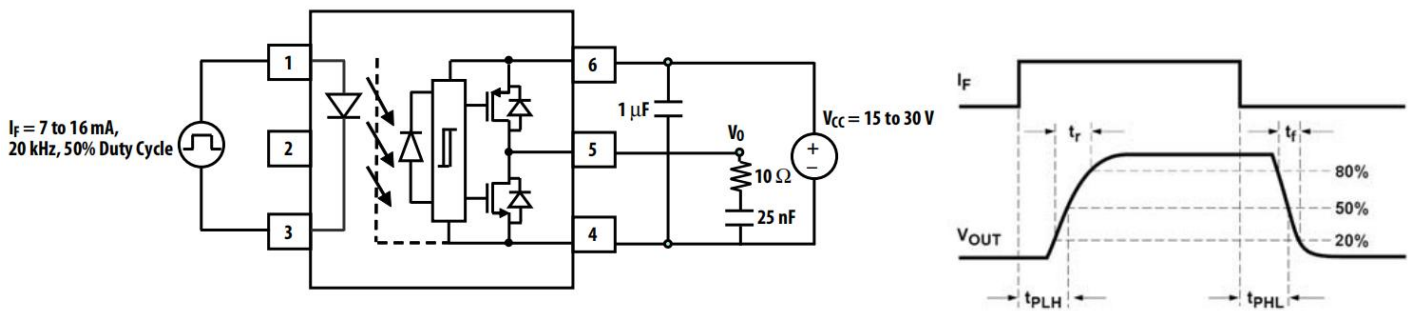

Figure 26.  $t_{PHL}$ ,  $t_{PHL}$ ,  $t_r$  and  $t_f$  test circuit and waveforms

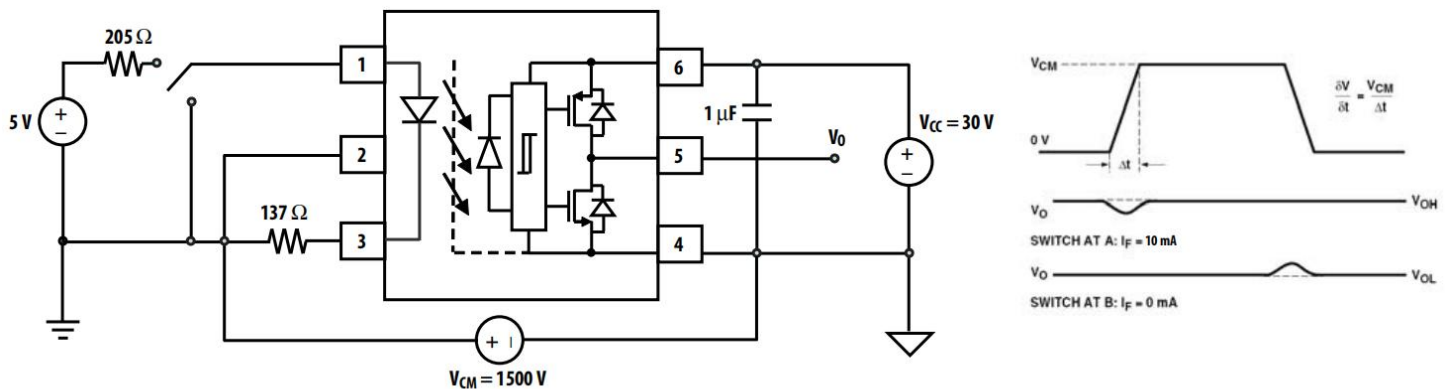

Figure 27. CMR test circuit with split resistors network and waveforms