



ORIENT

Photo coupler

Product Data Sheet

Part Number: OR-340

Customer: _____

Date: _____

SHENZHEN ORIENT COMPONENTS CO., LTD

Block A 3rd Floor No.4 Building, Tian'an Cyber Park, Huangge Rd, LongGang Dist, Shenzhen, GD

TEL: 0755-29681816

FAX: 0755-29681200

www.orient-opto.com

1. Features

- (1) 1.0 A maximum peak output current
- (2) 0.8 A minimum peak output current
- (3) Rail-to-rail output voltage
- (4) 200 ns maximum propagation delay
- (5) 100 ns maximum propagation delay difference
- (6) LED current input with hysteresis
- (7) 35 kV/ s minimum Common Mode Rejection (CMR) at $V_{CM} = 1500 V$
- (8) $I_{CC} = 3.0 mA$ maximum supply current
- (9) Under Voltage Lock-Out protection (UVLO) with hysteresis
- (10) Wide operating V_{CC} Range: 15 to 30 V
- (11) Industrial temperature range: $-40^{\circ}C$ to $105^{\circ}C$
- (12) Safety approval
 - UL approved(No.E323844)
 - VDE approved(No.40029733)
 - CQC approved (No.CQC19001231480)
- (13) In compliance with RoHS, REACH standards
- (14) MSL Level 1

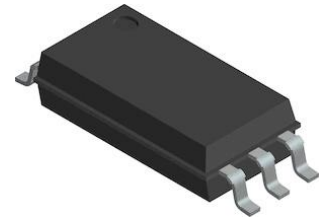

2. Description

The OR-340 contains an AlGaAs LED, which is optically coupled to an integrated circuit with a power output stage. This optocoupler is ideally suited for driving power IGBTs and MOSFETs used in motor control inverter applications. The high operating voltage range of the output stage provides the drive voltages required by gate controlled devices. The voltage and high peak output current supplied by this optocoupler make it ideally suited for direct driving IGBT with ratings up to 1200 V/ 50 A. For IGBTs with higher ratings, this optocoupler can be used to drive a discrete power stage which drives the IGBT gate.

3. Application Range

- (1)IGBT/MOSFET gate drive
- (2)AC and Brushless DC motor drives
- (3)Renewable energy inverters
- (4)Industrial inverters
- (5)Switching power supplies

4. Functional Diagram

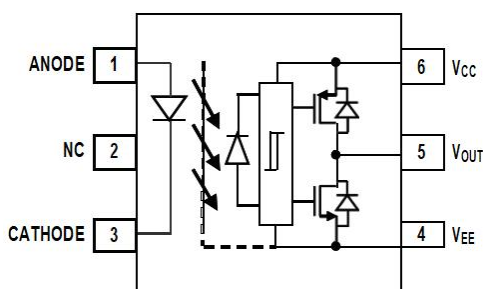

Note: A 1 μF bypass capacitor must be connected between pins V_{CC} and V_{EE} .

Truth Table			
LED	$V_{CC} - V_{EE}$ "POSITIVE GOING" (i.e., TURN-ON)	$V_{CC} - V_{EE}$ "NEGATIVE GOING" (i.e., TURN-OFF)	VO
OFF	0 – 30 V	0 – 30 V	LOW
ON	0 – 12.1 V	0 – 11.1 V	LOW
ON	12.1 – 13.5 V	11.1 – 12.4 V	TRANSITION
ON	13.5 – 30 V	12.4 – 30 V	HIGH

5. Absolute Maximum Ratings (Ta=25°C)

Parameter		Symbol	Rated Value	Unit
Input	Average Forward Input Current	I_F	25	mA
	Reverse Input Voltage	V_R	5	V
Output	“High” Peak Output Current	$I_{OH(PEAK)}$	1	A
	“Low” Peak Output Current	$I_{OL(PEAK)}$	1	A
	Output Collector Power Dissipation	P_O	700	mW
Total Power Dissipation		P_T	745	mW
Total Output Supply Voltage		$V_{CC} - V_{EE}$	35	V
Input Current (Rise/Fall Time)		$t_{r(IN)} / t_{f(IN)}$	500	ns
Insulation Voltage		V_{iso}	5000	Vrms
Working Temperature		T_{opr}	-40 ~ + 105	°C
Storage Temperature		T_{stg}	-55 ~ + 125	
*2 Soldering Temperature		T_{sol}	260	

*1. Room temperature = 25 °C. Exceeding the maximum absolute rating can permanently damage the device. Working long hours at the maximum absolute rating can affect reliability.

*2. soldering time is 10 seconds.

6. Electrical Optical Characteristics at Ta=25°C

Parameter	Symbol	Min.	Typ.	Max.	Units	Conditions
High Level Output Current	I_{OH}	-0.3	—	—	A	$V_O = (V_{CC} - 4V)$
		-0.8	—	—		$V_{CC} - V_O \leq 15V$
Low Level Output Current	I_{OL}	0.3	—	—	A	$V_O = (V_{EE} + 2.5V)$
		0.8	—	—		$V_{CC} - V_O \leq 15V$
High Level Output Voltage	V_{OH}	$(V_{CC} - 0.3)$	$(V_{CC} - 0.2)$	—	V	$I_O = -100 \text{ mA}$
		—	V_{CC}	—	V	$I_O = 0 \text{ mA}, I_F = 10 \text{ mA}$
Low Level Output Voltage	V_{OL}	—	0.1	0.2	V	$I_O = 100 \text{ mA}$
High Level Supply Current	I_{CCH}	—	1.9	3.0	mA	$R_g = 10 \Omega, C_g = 25 \text{ nF}, I_F = 10 \text{ mA}$
Low Level Supply Current	I_{CCL}	—	1.9	3.0	mA	$R_g = 10 \Omega, C_g = 25 \text{ nF}, V_F = 0 \text{ V}$
Threshold Input Current Low to High	I_{FLH}	—	1.5	4.0	mA	$R_g = 10 \Omega, C_g = 25 \text{ nF}, V_O > 5 \text{ V}$
Threshold Input Voltage High to Low	V_{FHL}	0.8	—	—	V	
Input Forward Voltage	V_F	1.2	1.55	1.95	V	$I_F = 10 \text{ mA}$
Temperature Coefficient of Forward Voltage	$\Delta V_F / \Delta T_A$	—	-1.7	—	mV/°C	$I_F = 10 \text{ mA}$
Input Reverse Breakdown Voltage	B_{VR}	5	—	—	V	$I_R = 100 \mu\text{A}$
Input Capacitance	C_{IN}	—	70	—	pF	$f = 1 \text{ MHz}, V_F = 0V$
UVLO Threshold	V_{UVLO+}	12.1	12.8	13.5	V	$V_O > 5 \text{ V}$ $I_F = 10 \text{ mA}$
	V_{UVLO-}	11.1	11.8	12.4		
UVLO Hysteresis	U_{VLOHYS}	—	1.0	—		

7. Switching Characteristics

Parameter	Symbol	Min.	Typ	Max.	Units	Test Conditions
Propagation Delay Time to High Output Level	t_{PLH}	50	98	200	ns	$R_g = 10 \Omega, C_g = 25nF,$ $f = 20 \text{ kHz},$ Duty Cycle = 50%, $I_F = 7 \text{ mA to } 16 \text{ mA},$ $V_{CC} = 15V \text{ to } 30V$
Propagation Delay Time to Low Output Level	t_{PHL}	50	95	200	ns	
Pulse Width Distortion	PWD	—	22	70	ns	
Propagation Delay Difference Between Any Two Parts	PDD ($t_{PHL} - t_{PLH}$)	-100	—	100	ns	
Rise Time	t_r	—	43	—	ns	$V_{CC} = 30 \text{ V}$
Fall Time	t_f	—	40	—	ns	
Output High Level Common Mode Transient Immunity	$ CM_H $	35	50		kV/ μ s	$T_A = 25^\circ \text{ C}, I_F = 10 \text{ mA}, V_{CC} = 30 \text{ V}, V_{CM} = 1500 \text{ V}$ with split resistors
Output Low Level Common Mode Transient Immunity	$ CM_L $	35	50	—		$T_A = 25^\circ \text{ C}, V_F = 0 \text{ V}, V_{CC} = 30 \text{ V}, V_{CM} = 1500 \text{ V}$ with split resistors

8. Order Information

Part Number

OR-340U-Y-Z

Note

340= Part Number

U = Lead form option (W or W1)

Y = Tape and reel option (TA,TA1 or none).

Z = 'V' code for VDE safety (This options is not necessary).

* VDE Code can be selected.

Option	Description	Packing quantity
S(TA)	Surface mount lead form (low profile) + TA tape & reel option	1000 units per reel
S(TA1)	Surface mount lead form (low profile) + TA1 tape & reel option	1000 units per reel

9. Naming Rule

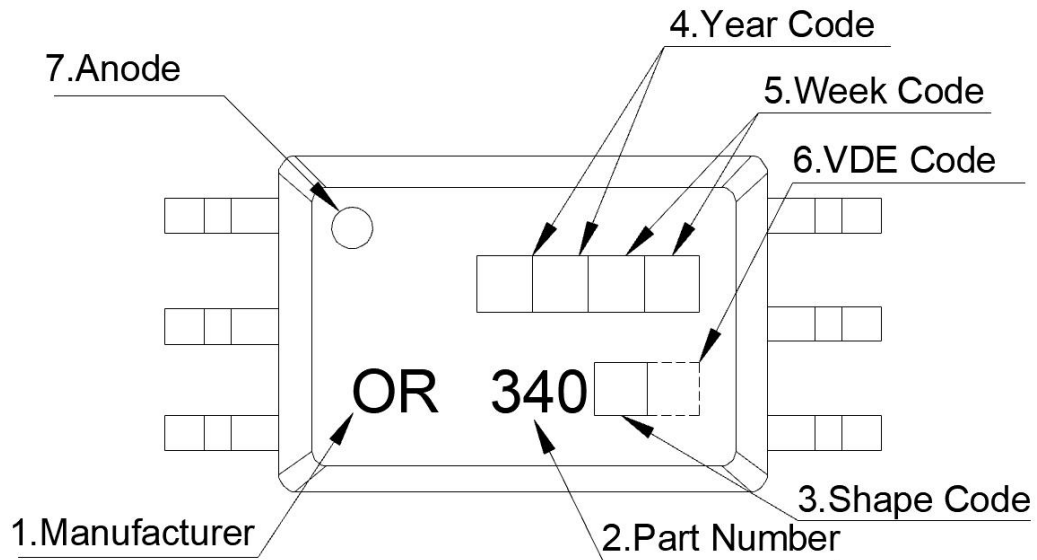

1. Manufacturer : ORIENT.
2. Part Number : 340 .
3. Shape Code : Lead form option ,W or W1
4. Year Code : '21' means '2021' and so on.
5. Week Code : 01 means the first week, 02 means the second week and so on.
6. VDE Code . (Optional)
7. Anode.

* VDE Mark can be selected.

10. Package Dimension

(1).OR-340W

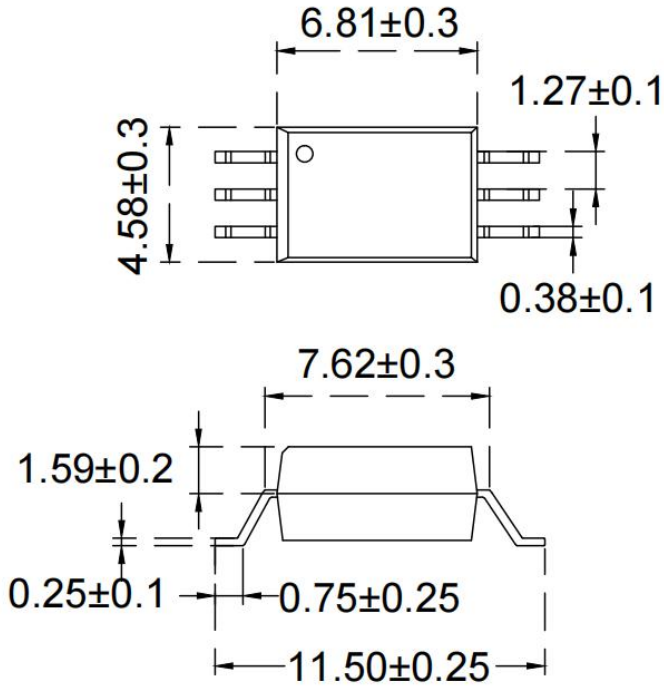

Land Pattern Recommendation

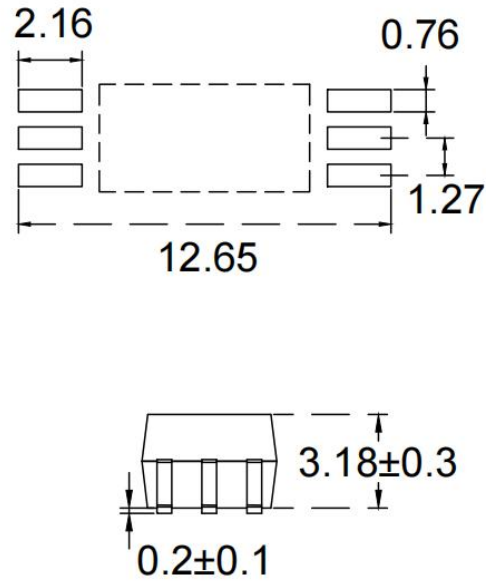

(2).OR-340W1

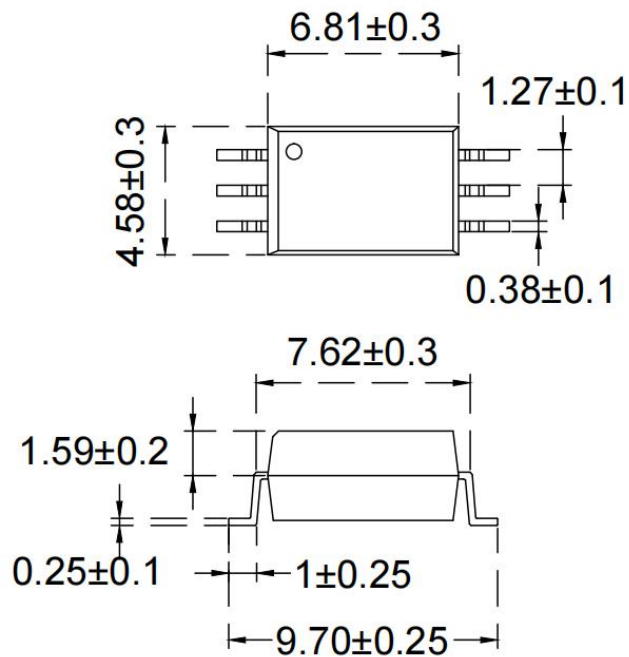

Land Pattern Recommendation

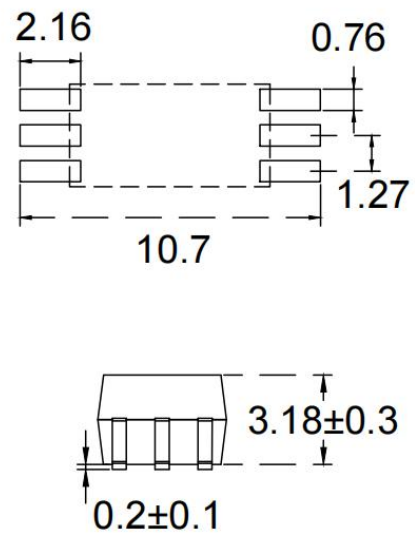

11. Taping Dimensions

(1)OR-340W-TA

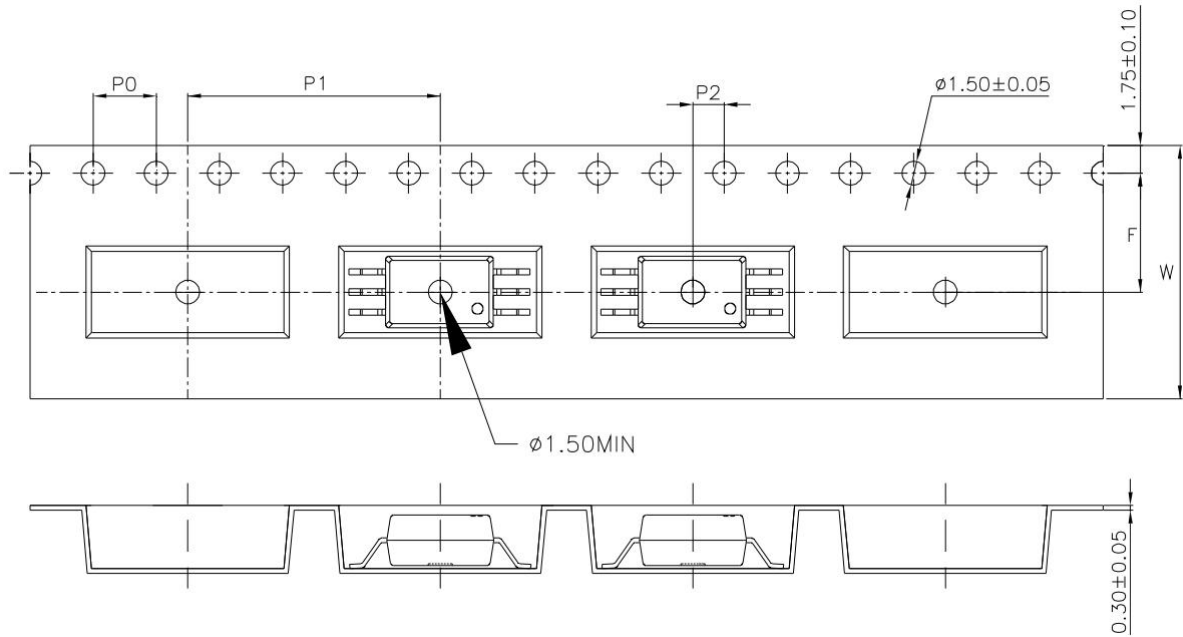

(2)OR-340W-TA1

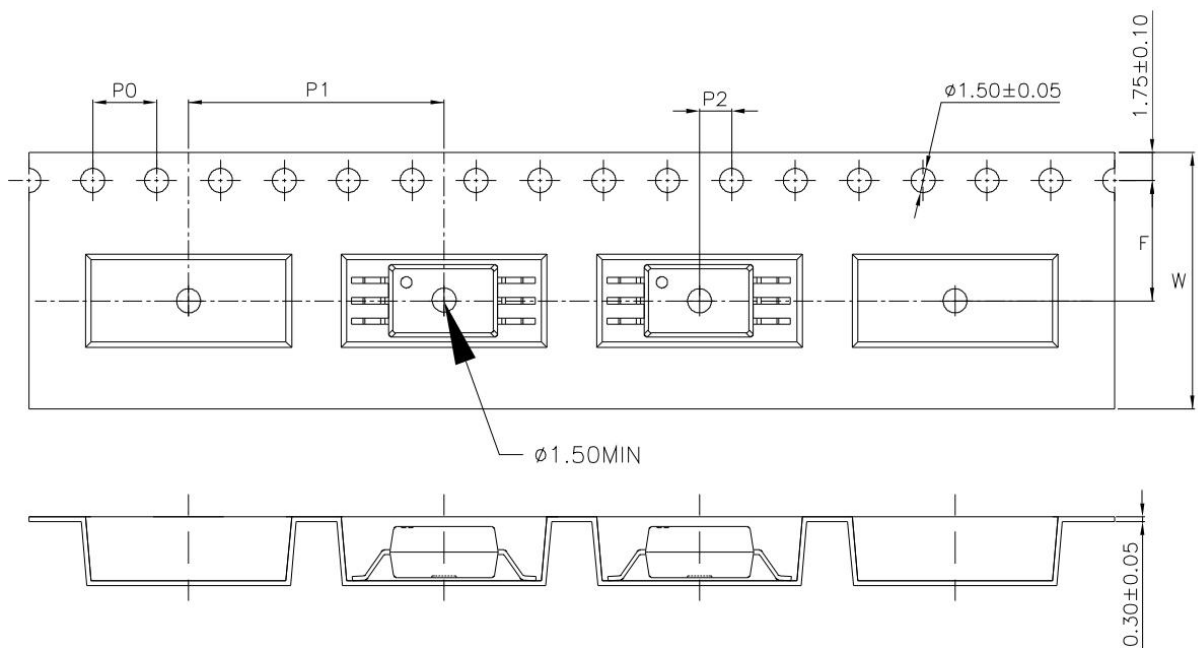

(1)OR-340W1-TA

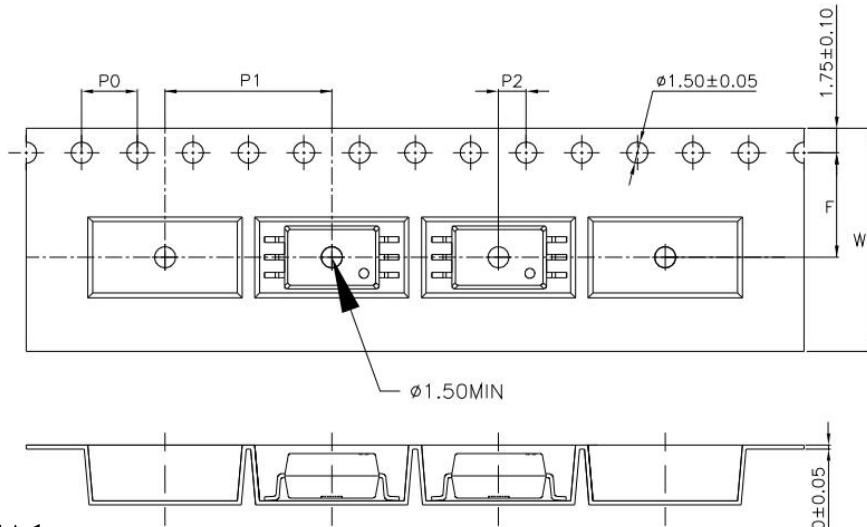

(2)OR-340W1-TA1

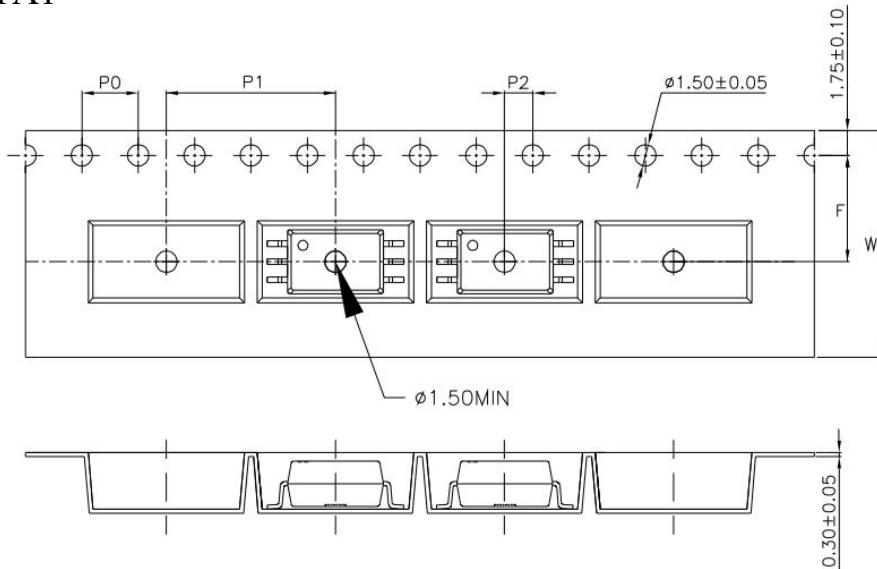

Type	symbol	Dimension in mm (inch) For W type	Dimension in mm (inch) For W1 type
bandwidth	W	16 ± 0.3 (0.63)	16 ± 0.3 (0.63)
pitch	P0	4 ± 0.1 (0.16)	4 ± 0.1 (0.16)
pitch	F	7.5 ± 0.1 (0.3)	7.5 ± 0.1 (0.3)
	P2	2 ± 0.1 (0.079)	2 ± 0.1 (0.079)
interval	P1	16 ± 0.1 (0.63)	12 ± 0.1 (0.47)

Encapsulation type	TA/TA1
amount (pcs)	1000

12. Package Dimension

(1) package dimension

Packing Information	
Packing type	Reel type
Tape Width	16mm
Qty per Reel	1,000pcs
Small box (inner) Dimension	345*345*58.5mm
Large box (Outer) Dimension	620x360x360mm
Max qty per small box	2,000pcs
Max qty per large box	20,000pcs

(2)Packing Label Sample



Note:

1. Material Code :Product ID.
2. P/N :Contents with "Order Information" in the specification.
3. Lot No. :Product data.
4. D/C :Product weeks.
5. Quantity :Packaging quantity.

13. Temperature Profile Of Soldering

(1).IR Reflow soldering (JEDEC-STD-020C compliant)

One time soldering reflow is recommended within the condition of temperature and time profile shown below. Do not solder more than three times.

Profile item	Conditions
Preheat	
- Temperature Min (T Smin)	150°C
- Temperature Max (T Smax)	200°C
- Time (min to max) (ts)	90±30 sec
Soldering zone	
- Temperature (TL)	217°C
- Time (t L)	60 sec
Peak Temperature	260°C
Peak Temperature time	20 sec
Ramp-up rate	3°C / sec max.
Ramp-down rate from peak temperature	3~6°C / sec
Reflow times	≤3

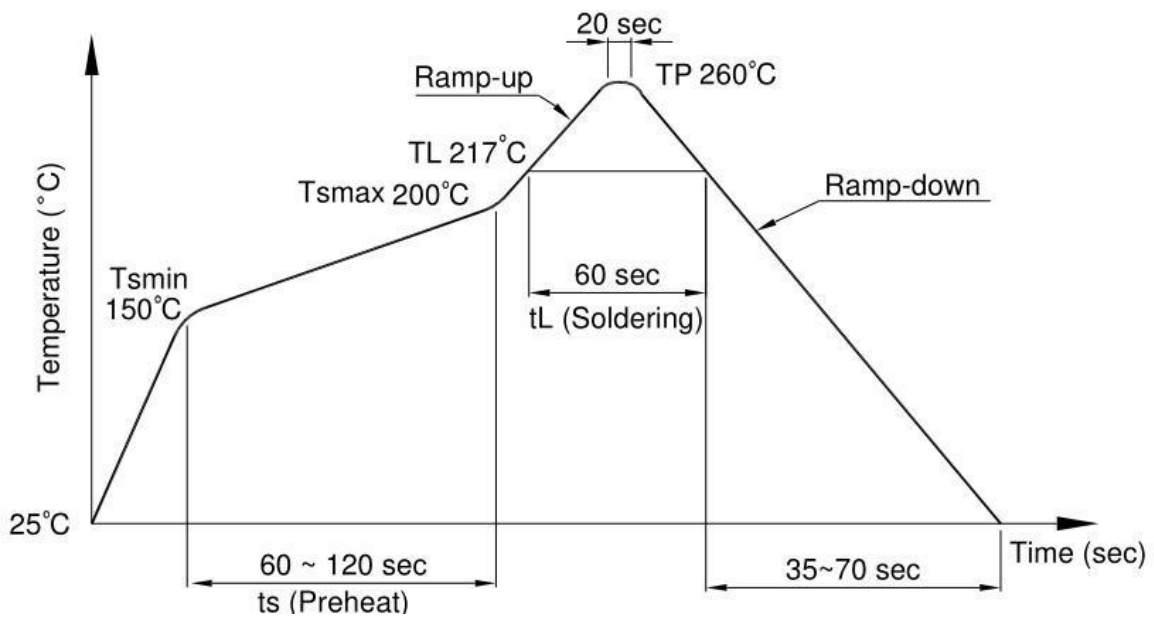

(3) .Wave soldering (JEDEC22A111 compliant)

One time soldering is recommended within the condition of temperature.

Temperature	260+0/-5°C
Time	10 sec
Preheat temperature	5 to 140°C
Preheat time	30 to 80 sec

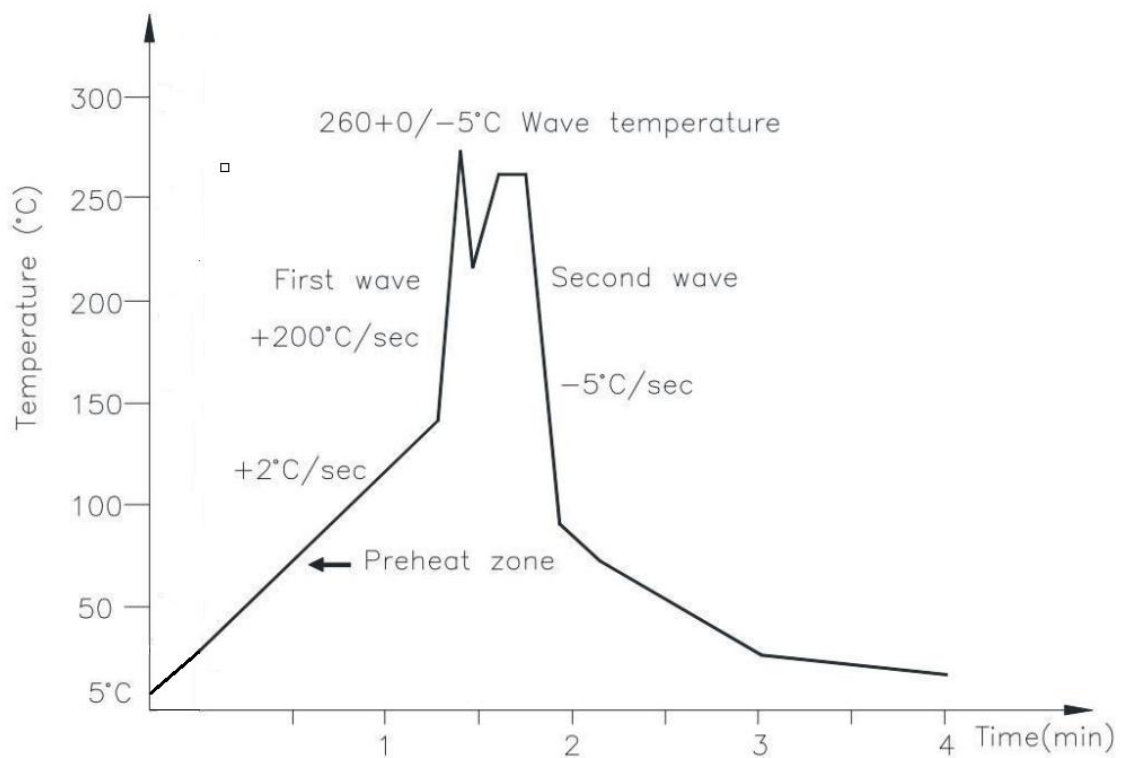

(3).Hand soldering by soldering iron

Allow single lead soldering in every single process. One time soldering is recommended.

Temperature	380+0/-5°C
Time	3 sec max

14. CHARACTERISTICS CURVES (TYPICAL PERFORMANCE)

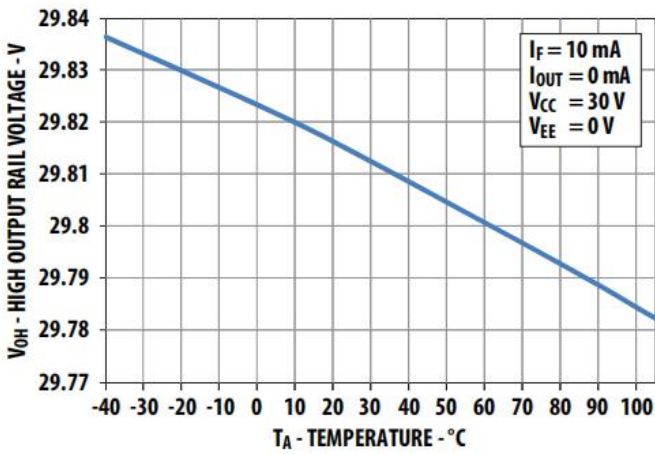

Figure 1. High output rail voltage vs. temperature

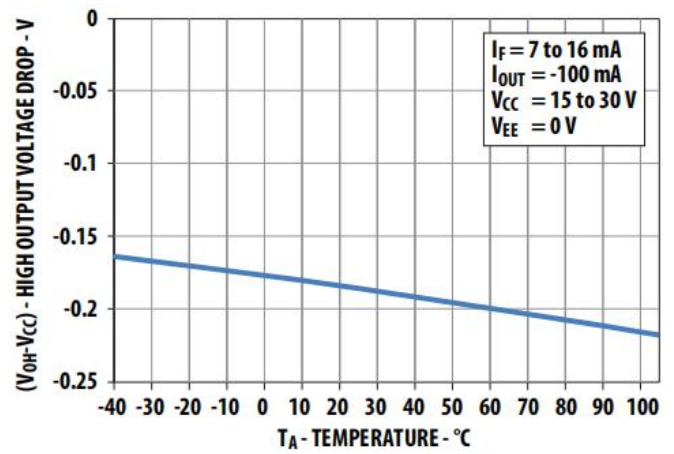

Figure 2. V_{OH} vs. temperature

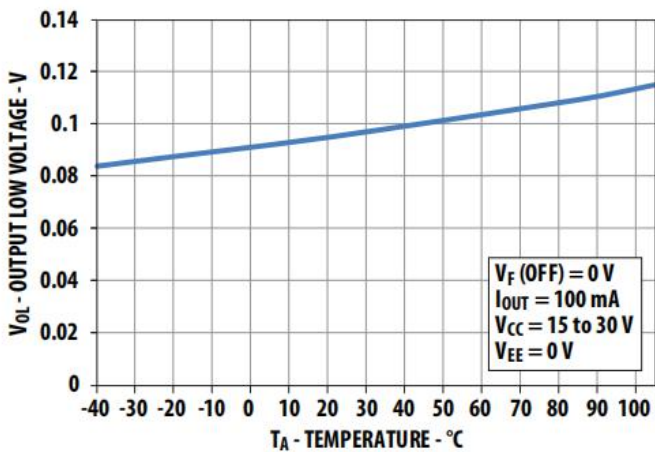

Figure 3. V_{OL} vs. temperature

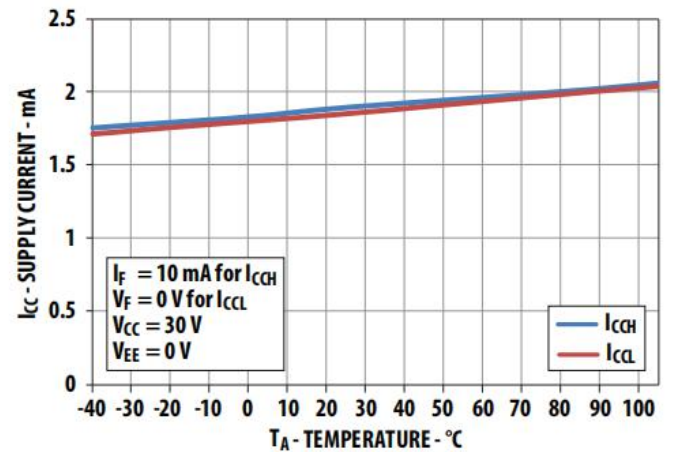

Figure 4. I_{CC} vs. temperature

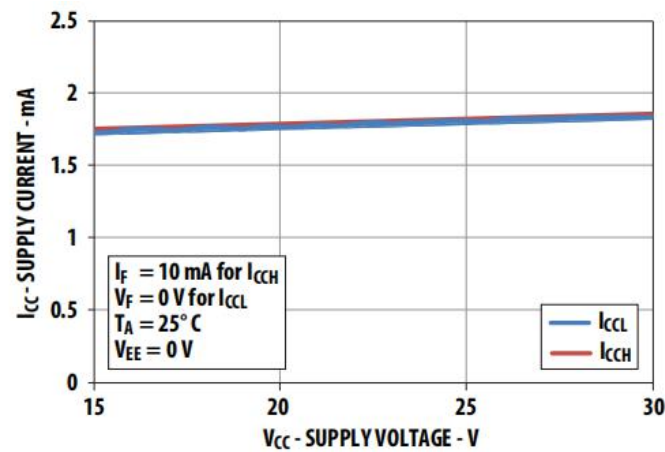

Figure 5. I_{CC} vs. V_{CC}

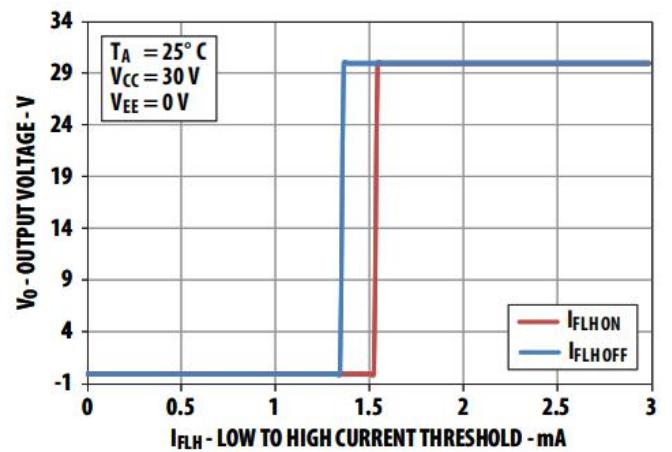

Figure 6. I_{FLH} hysteresis

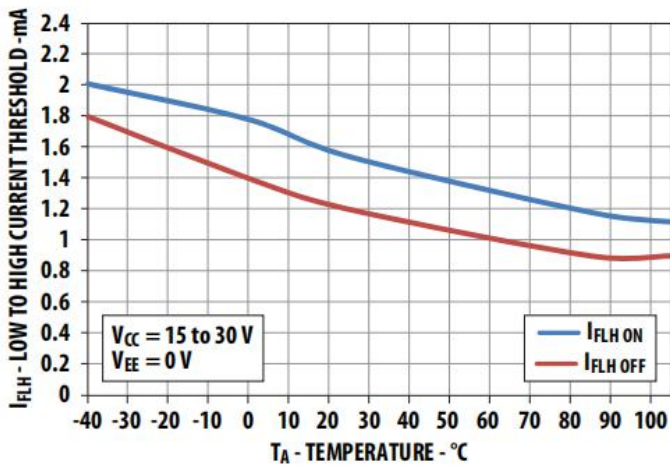

Figure 7. I_{FLH} vs. temperature

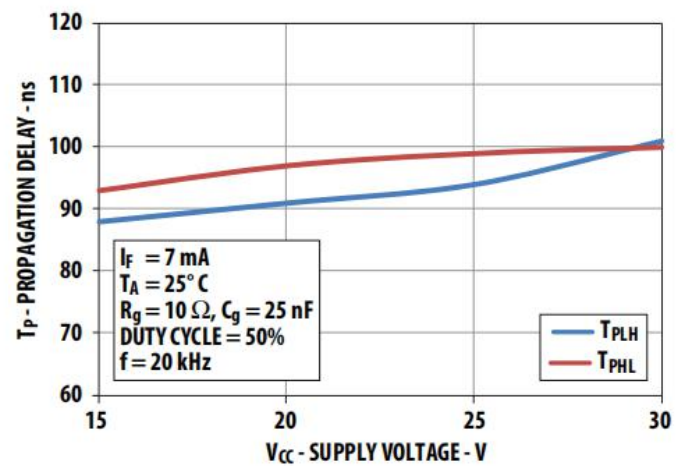

Figure 8. Propagation delays vs. V_{CC}

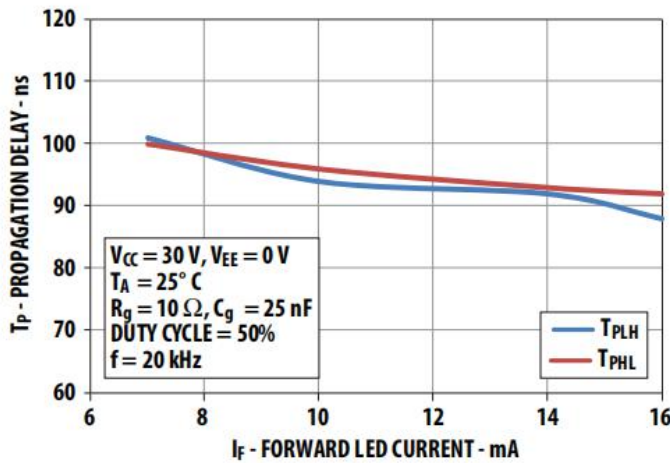

Figure 9. Propagation delays vs. I_F

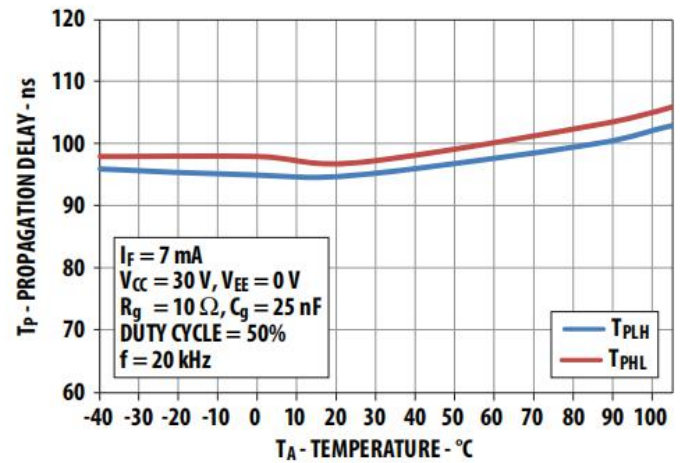

Figure 10. Propagation delays vs. temperature

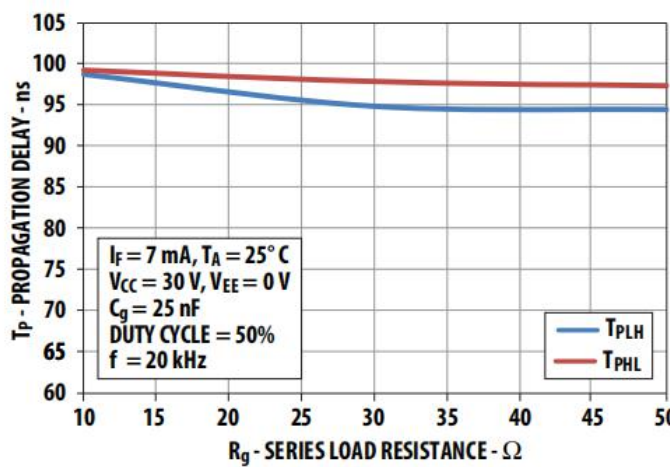

Figure 11. Propagation delay vs. R_g

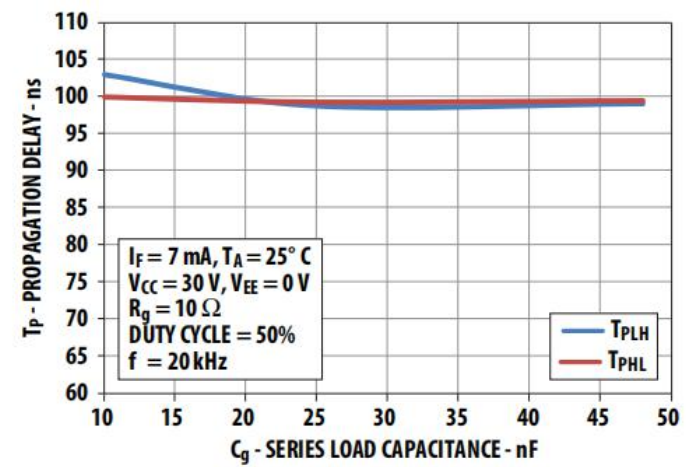

Figure 12. Propagation delay vs. C_g

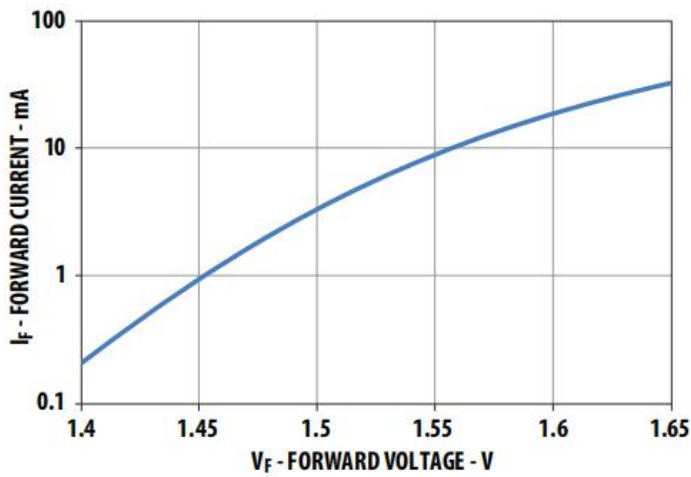

Figure 13. Input current vs. forward voltage

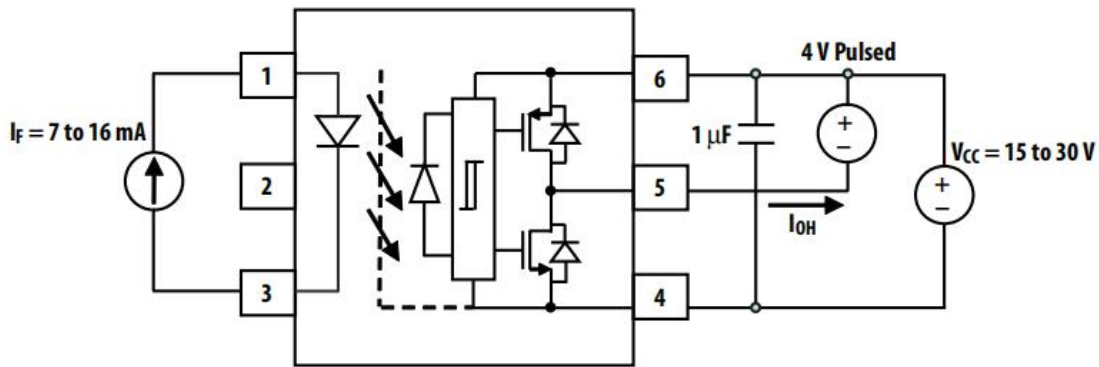

Figure 14. I_{OH} test circuit

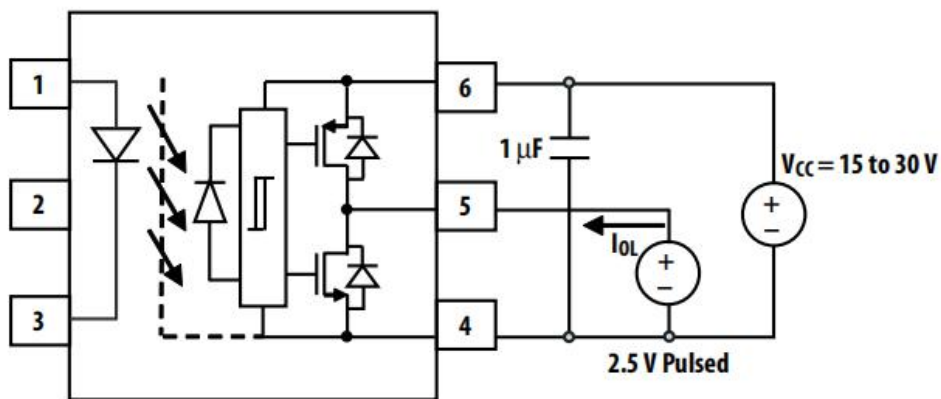

Figure 15. I_{OL} test circuit

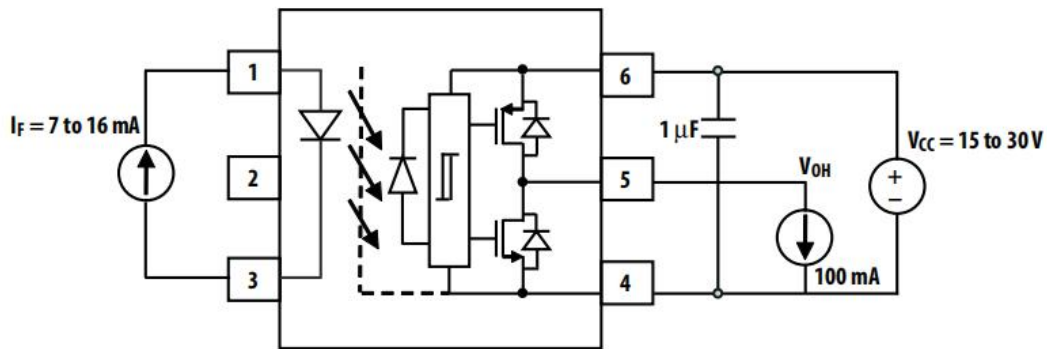

Figure 16. V_{OH} test circuit

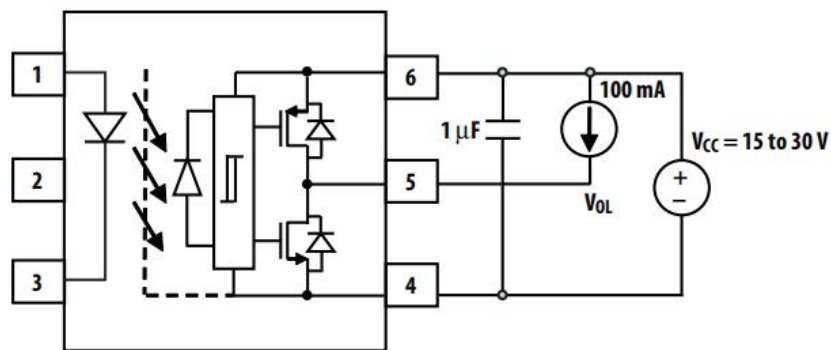

Figure 17. V_{OL} test circuit

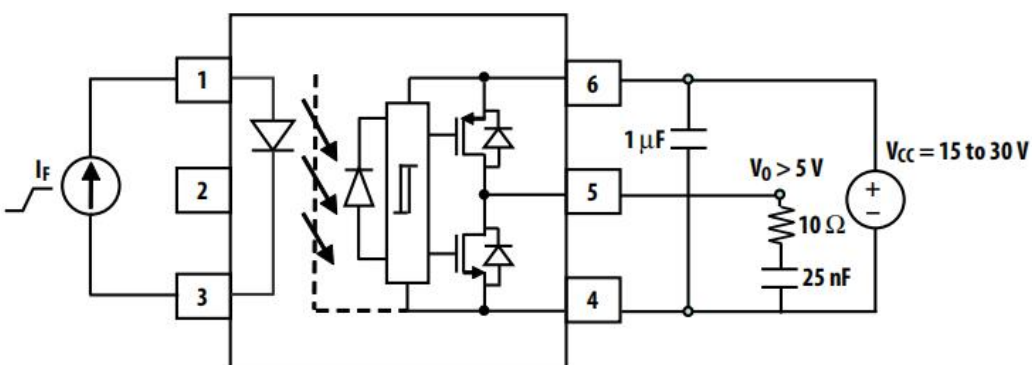

Figure 18. I_{FLH} test circuit

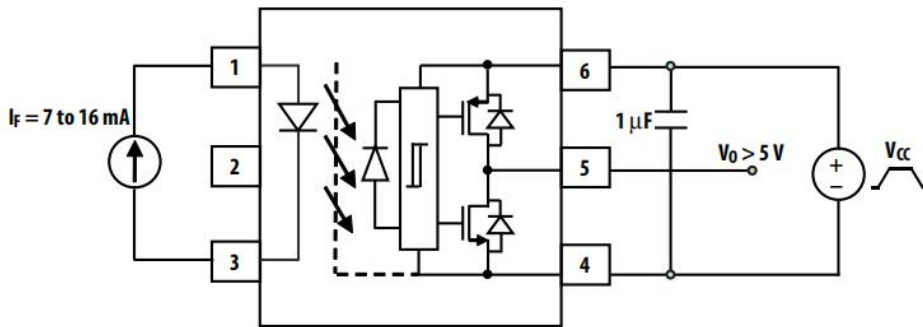

Figure 19. UVLO test circuit

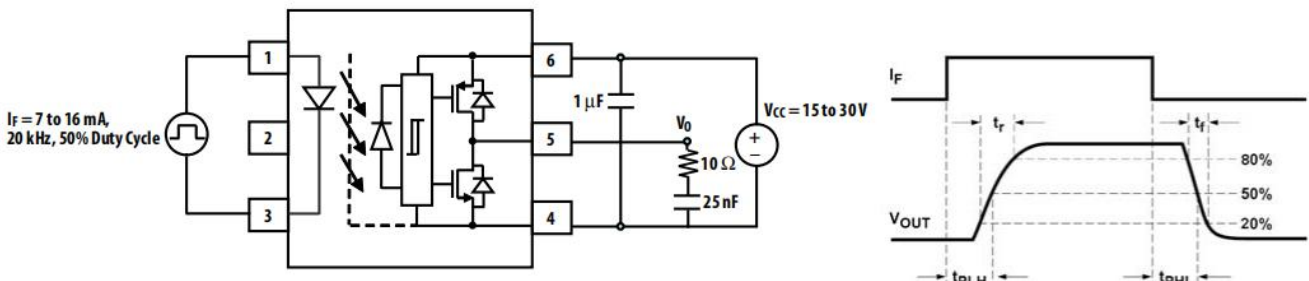

Figure 20. t_{PHL} , t_{PHL} , t_r and t_f test circuit and waveforms

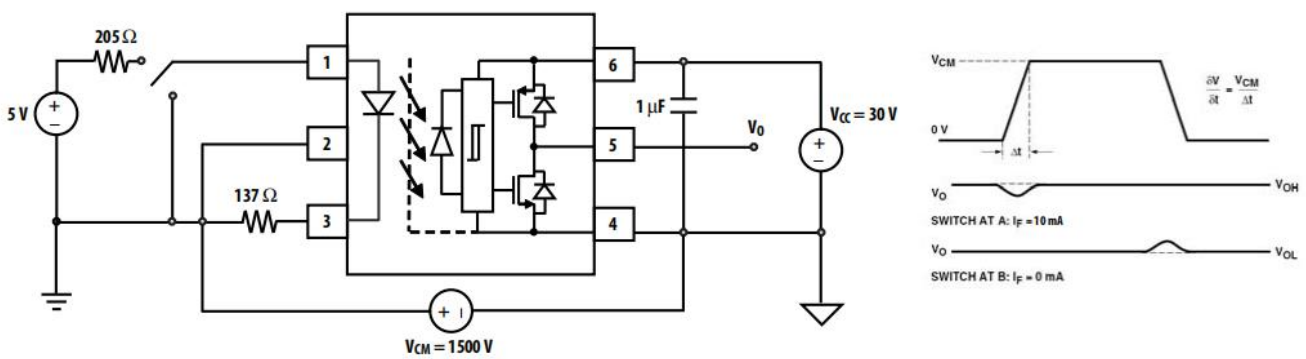

Figure 21. CMR test circuit with split resistors network and waveforms