



SPECIFICATION

Customer Name					
Customer No.					
Product Description			Photo Interrupter		
Product Model			ORTR-352		
Orient Confirm			Customer Confirm		
Approved by	Checked by	Prepared by	Approved by	Quality	Engineering
Linshixiu	Sushiheng	Zhaowanbao			
Judge outcome :		OK	Judge outcome :		



Add : Building 1,21 Jinhui Road, Jianghai district, Jiangmen

TEL : +86-750-3697838

URL : www.orient-opto.com



1、Features

- 3.0mm space for interruption.
- Easy to mount on PCB.
- High-speed response.
- Widely applicable.



2、Applications

- Tape-end sensors.
- Timing sensors.
- Edge sensors.
- Copiers.

3、Description

The ORTR-352 is a high performance standard type photo interrupter, which combines high output GaAIAs infrared light emitting diode and high sensitive phototransistor.

4、Package Outline Dimensions

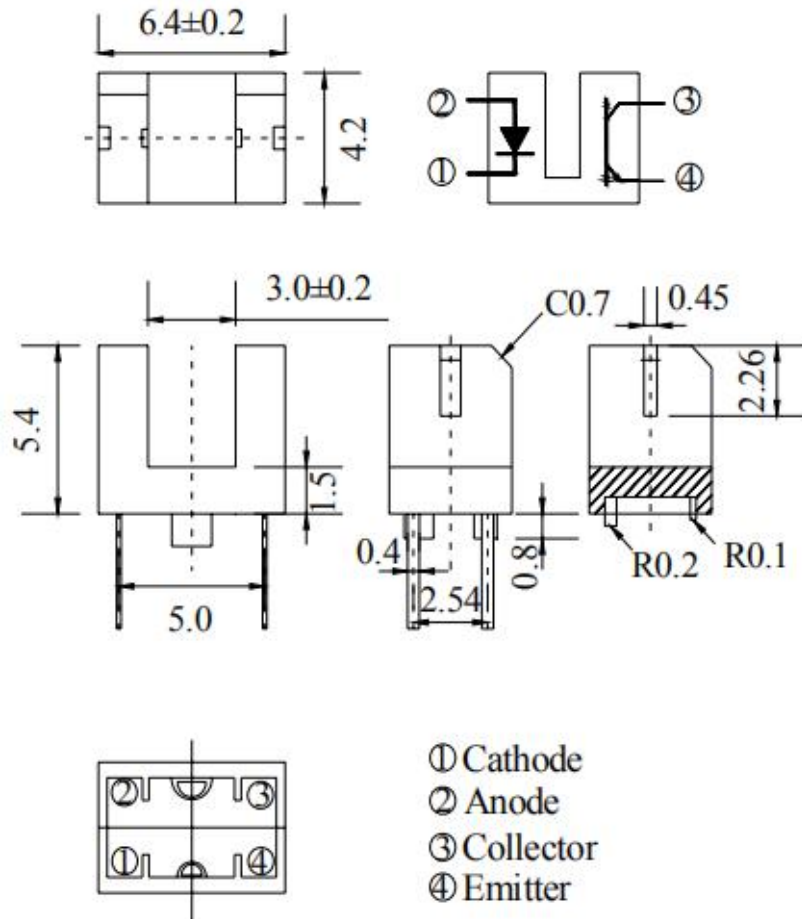

Notes:

- 1). All dimensions are in millimeters (inches).
- 2). Tolerance is ± 0.2 mm unless otherwise specified.
- 3). Specifications are subject to change without notice.

**5、 Absolute maximum ratings at Ta=25°C**

	Parameter	Symbol	Rating	Unit
Input	Power Dissipation	P_D	100	mW
	Forward Current	I_F	100	mA
	Peak Forward Current* ¹	I_{FP}	1	A
	Reverse Voltage	V_R	5	V
Output	Collector Power Dissipation	P_C	100	mW
	Collector Current	I_C	20	mA
	C-E Voltage	V_{CEO}	30	V
	E-C Voltage	V_{ECO}	5	V
Operating Temperature Range		T_{opr}	-25~+85	°C
Storage Temperature Range		T_{stg}	-40~+100	°C
Soldering Temperature* ²		T_{sld}	260	°C
Electrostatic Discharge		ESD	2000(HBM)	V

Notes: *¹Condition for I_{FP} is pulse of 1/10 duty and 0.1msec width.

*²Soldering time \leq 5 seconds.



6、Electrical-optical characteristics at Ta=25°C

Parameter	Symbol	Condition	Min.	Typ.	Max.	Unit	
Input	Forward Voltage	V_F	$I_F=20\text{mA}$	1.0	1.2	1.6	V
	Capacitance	C	$V=0\text{V}$ $f=1\text{kHz}$	-	25	-	pF
	Reverse Current	I_R	$V_R=5\text{V}$	-	-	10	uA
	Peak Wave Length	λ_P	$I_F=20\text{mA}$	-	940	-	nm
Output	Collector Dark Current	I_{CEO}	$V_{CE}=20\text{V}$	-	-	100	nA
	Light Current	I_L	$V_{CE}=5\text{V}$ $I_F=20\text{mA}$	1.0	-	4.0	mA
	C-E Saturation Voltage	$V_{CE(sat)}$	$I_F=20\text{mA}$ $I_C=0.5\text{mA}$	-	-	0.4	V
Switching Speeds	Rise Time	t_r	$V_{CC}=5\text{V}$ $I_C=2\text{mA}$	-	15	-	us
	Fall Time	t_f	$R_L=1000\ \Omega$	-	15	-	us

Notes:

- 1、Tolerance of light current is $\pm 15\%$.
- 2、Tolerance of forward voltage is $\pm 0.1\text{V}$.

7 · Typical optical characteristics curves

Light Current vs Collector-Emitter Voltage

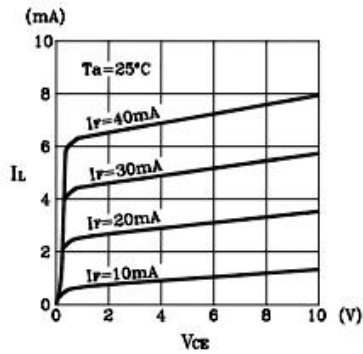

Forward Current vs Forward Voltage

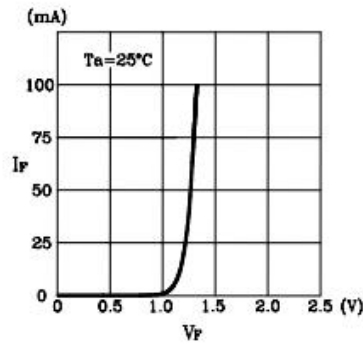

Power Dissipation vs Ambient Temperature

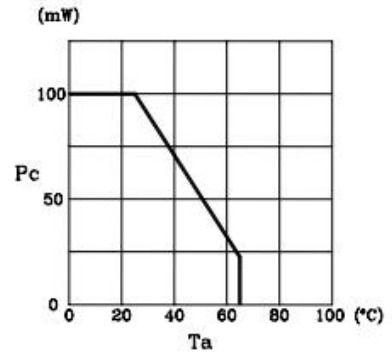

Dark Current vs Ambient Temperature

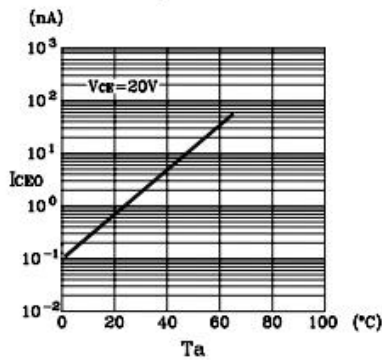

Light Current vs Forward Current

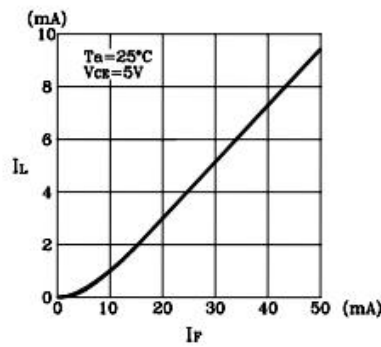

Relative Light Current vs Ambient Temperature

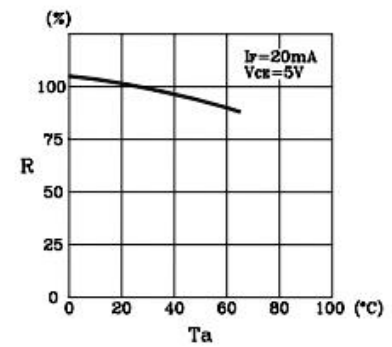

Response Time vs Load Resistance

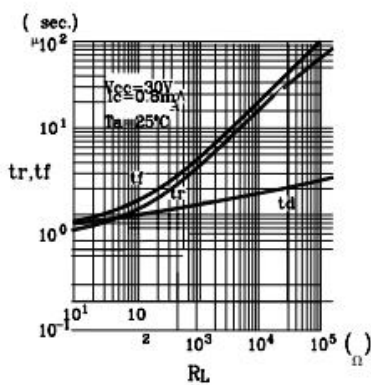

Position Detect Characteristics

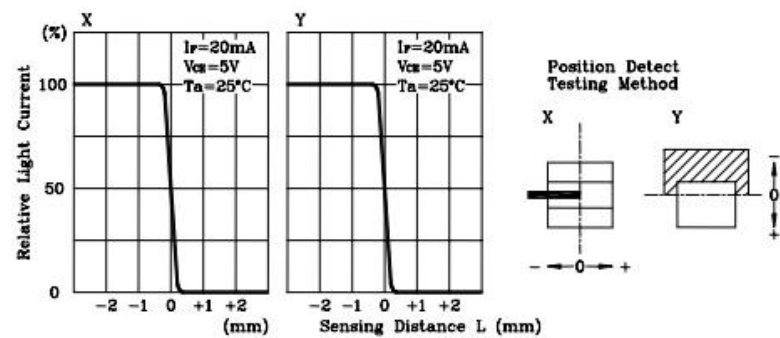

Response Time Test Conditions

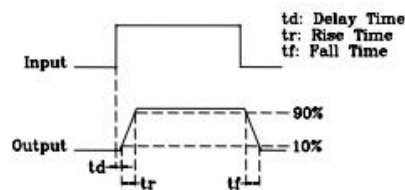
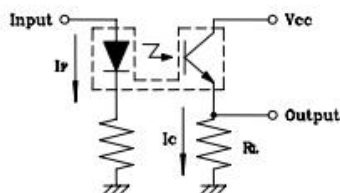

8、Judgment criteria of failure for the reliability

Measuring items	Symbol	Measuring conditions	Judgement criteria for failure
Forward voltage	VF (V)	IF=20mA	Initial Level*1.1
Reverse current	IR(μA)	VR=5V	Over Ux2
Luminous intensity	Iv (mcd)	IF=20mA	Initial Level*0.7

Note: 1).U means the upper limit of specified characteristics. S means initial value.

2).Measurement shall be taken between 2 hours and after the test pieces have been returned to normal ambient conditions after completion of each test.

9、Packaging Box Dimensions (Units: mm)

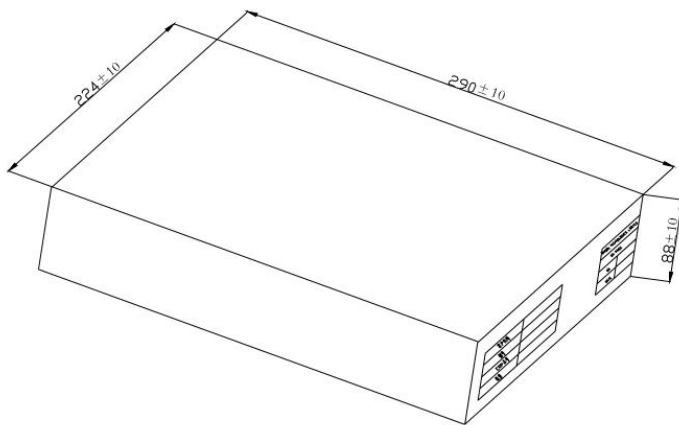

10、Packaging Bag Dimensions

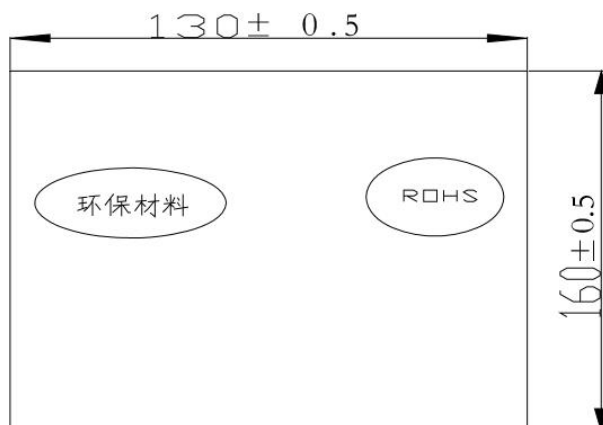

Notes:

- 1.100pcs per bag, 1Kpcs per box
- 2.All dimensions are in millimeters
- 3.Specifications are subject to change without notice



11 、 Package and Label of Products

- (1) 100PCS/1Bag, 10Bags/1Box
- (2) Label:

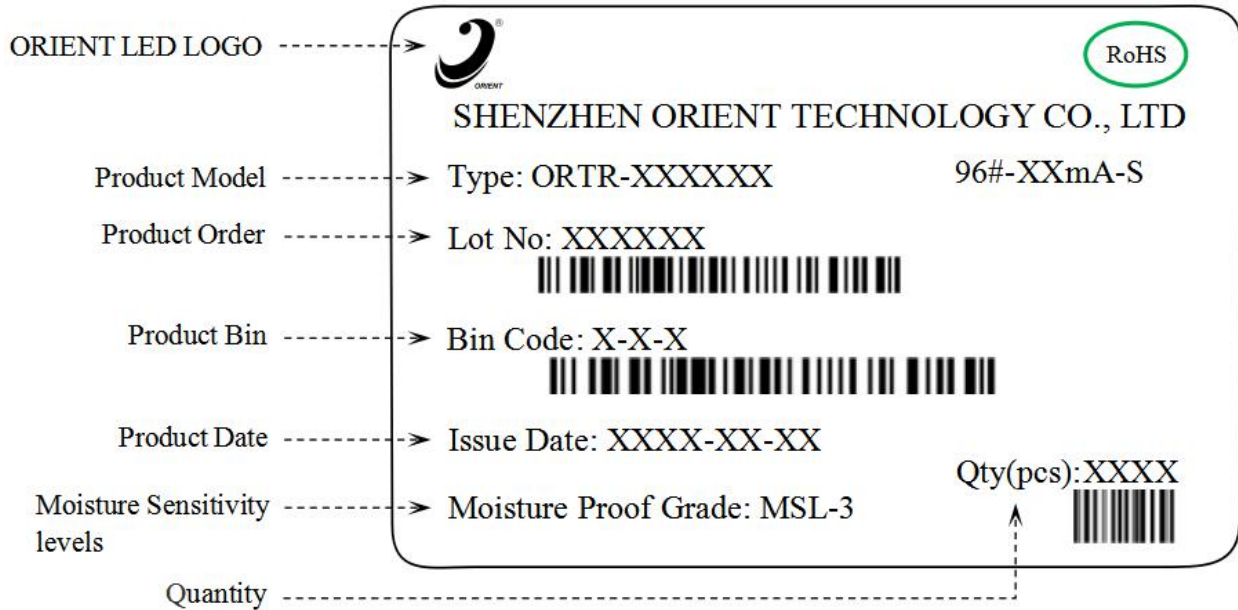



12 · Reliability Test

Classification	Test Item	Reference Standard	Test Conditions	Result
Endurance Test	Operation Life	MIL-STD-750D:1026 MIL-STD-883D:1005 JIS-C-7021 :B-1	Connect with a power $I_f=20\text{mA}$ T_a =Under room temperature Test time=1,000hrs	0/20
	High Temperature High Humidity Storage	MIL-STD-202F:103B JIS-C-7021 :B-11	$T_a=+100^\circ\text{C}\pm 5^\circ\text{C}$ RH=90%-95% Test time=240hrs	0/20
	High Temperature Storage	MIL-STD-883:1008 JIS-C-7021 :B-10	High $T_a=+100^\circ\text{C}\pm 5^\circ\text{C}$ Test time=1,000hrs	0/20
	Low Temperature Storage	JIS-C-7021 :B-11	Low $T_a=-40^\circ\text{C}\pm 5^\circ\text{C}$ Test time=1,000hrs	0/20
Environmental Test	Temperature Cycling	MIL-STD-202F:107D MIL-STD-750D:1051 MIL-STD-883D:1010 JIS-C-7021 :A-2	$-40^\circ\text{C} \sim +25^\circ\text{C} \sim +100^\circ\text{C} \sim +25^\circ\text{C}$ 30min 5min 30min 5min Test Time=10cycle	0/20
	Thermal Shock	MIL-STD-202F:107D MIL-STD-750D:1051 MIL-STD-883D:1011	$-40^\circ\text{C}\pm 5^\circ\text{C} \sim +100^\circ\text{C}\pm 5^\circ\text{C}$ 20min 20min Test Time=10cycle	0/20
	Solder Resistance	MIL-STD-202:201A MIL-STD-750:2031 JIS-C-7021 :A-1	Preheating : $140^\circ\text{C}-160^\circ\text{C}$, within 2 minutes. Operation heating : 260°C (Max.), within 10seconds. (Max.)	0/20



13 · Precautions for use

1 · Soldering

Careful attention should be paid during soldering. When soldering, leave more than 3mm from solder joint to epoxy bulb, and soldering beyond the base of the tie bar is recommended.

Recommended soldering conditions:

Hand Soldering		DIP Soldering	
Temp. at tip of iron	300°C Max. (30W Max.)	Preheat temp.	100°C Max. (60 sec Max.)
Soldering time	3 sec Max.	Bath temp. & time	260 Max., 5 sec Max
Distance	3mm Min. (From solder joint to epoxy bulb)	Distance	3mm Min. (From solder joint to epoxy bulb)

wave profile :

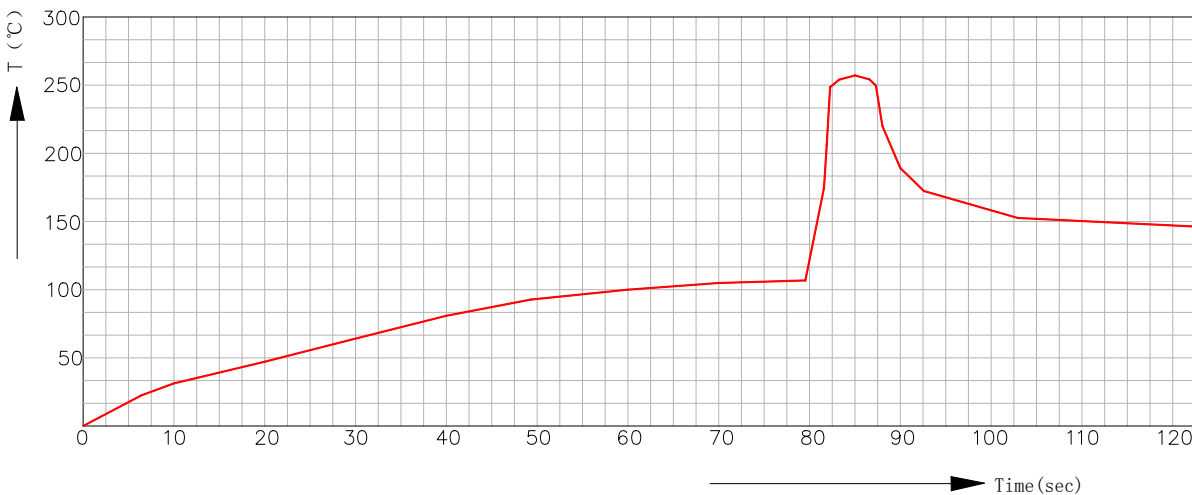

2 · Cleaning

2.1. Don't be cleaned with ultrasonic. Recommended to be wiped with isopropyl alcohol or pure alcohol, wiping time should not be more than one minute. LED must be placed at room temperature for fifteen minutes before using. After cleaning, you must insure clean on the radiant surface. Otherwise, foreign objects can affect radiant color.

2.2. LED can not be in contact with isoamyl acetate, trichloroethylene, acetone, sulfide, nitride, acid, alkali, salt. These matter can destroy LED.

3 · Sealing

3.1. Sealing glue can not contain sodium ion, sulfide, because these matter can affect fluorescence powder poisoning.

3.2. When using normal sealing glue, Recommended to be operated life for 168hrs under normal temperature.



4 · Storage

- 4.1. Don't open the moisture proof bag before ready to use the LEDs.
- 4.2. The LEDs should be kept at 30°C or less and 60%RH or less before opening the package. The max. storage period before opening the package is 1 year.
- 4.3. After opening the package, the LEDs should be kept at 30-35%RH or less, and it should be used within 3 days. If the LEDs should be kept at 30-35%RH or more, and it should be used within 4 hours.
- 4.4. If the LEDs be kept over the conditions of 20%, baking is required before mounting. Baking condition as below: 70±5°C for 12 hrs for bulk goods, 105±5°C for 1 hrs for roll goods.
- 4.5. The environment have no acid, alkali, corrosive gas, intensively shake and high magnetic field.

5 · Static

- 5.1. Static and Peak surge voltage can destroy LED, Avoiding Instantaneous voltage when turn on or turn off the lights.
- 5.2. Please wear Anti-static wrist band, Anti-static glove, Anti-static shoes in the course of operation, and the equipment must be grounded.

6 · Test

- 6.1. Customer must apply the current limiting resistor in the circuit so as to drive the LEDs within the rated current. Otherwise slight voltage shift maybe will cause big current change and burn out will happen.
- 6.2. Also, caution should be taken not to overload the LEDs with instantaneous high voltage at the turning ON and OFF of the circuit. Otherwise, The LEDs will be destroyed, testing methods as follows:
- 6.3. The reverse voltage mustn't exceed 5v when lighting on or testing the LED, otherwise, The LEDs will be damaged.

7 · Else

Radiant color of LEDs have a little change with the current, recommended that LED is used in series and resistance, when lighting, please don't see directly radiant surface of LED, otherwise LED will burn eyes.